

MINIATURE HIGH DENSITY SERIES

- DESCRIPTION AND MATERIAL
- 316 stainless steel passivated per QQ-P-35 Type VI with naval bronze engaging nut.
 - Special alloys are available upon request (contact factory).
 - Contains a removable glass reinforced epoxy insert. (Except for MHDG series and CCP's)
 - Up to 61 contacts.
 - Up to 600 VDC.
 - 10,000 PSI in mated condition (higher pressure rating available using special alloy metal shell; please contact factory).
 - Bulkhead connector design open face pressure rated to 5,000 psi.
 - MHD-CCR/CCP connectors can be overmolded with polyurethane.
 - Contacts are gold plated per MIL-G-45204.
- CABLE
- Connector's amperage and voltage may be limited by the amperage and voltage ratings of the cable to which the connector is molded.
 - This series is not molded to cable unless specified at the time of order.
- USES
- Signal telemetry.
 - Hazardous environment.
 - FCR is mounted by use of four equally spaced bolts around the flange surface.
 - FCR is used in place of the BCR when the use of a bulkhead nut and washer is impractical.
 - For all open face pressures above 5,000 PSI the BCR, FCR must be back potted (please contact the factory).
 - The CCR is used in a variety of environments where cable to cable termination is necessary.
- GUIDELINES
- Mounting torque should not exceed 150 in lbs. for this series.
 - All mounting surfaces require a 32 finish.
 - Align indexes.
 - Keep o-ring grooves clean.
 - Avoid o-ring cuts and nicks.
 - Lubricate o-rings with Dow Corning #111 Valve Lubricant or equivalent.
 - Replace o-rings when re-using connectors.
 - Avoid contact with noxious solvents.
 - Elastomers can be seriously degraded if exposed to direct sunlight or high ozone levels for extended periods of time.

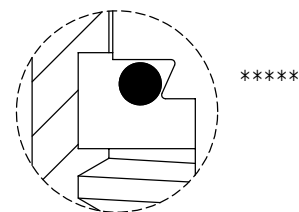
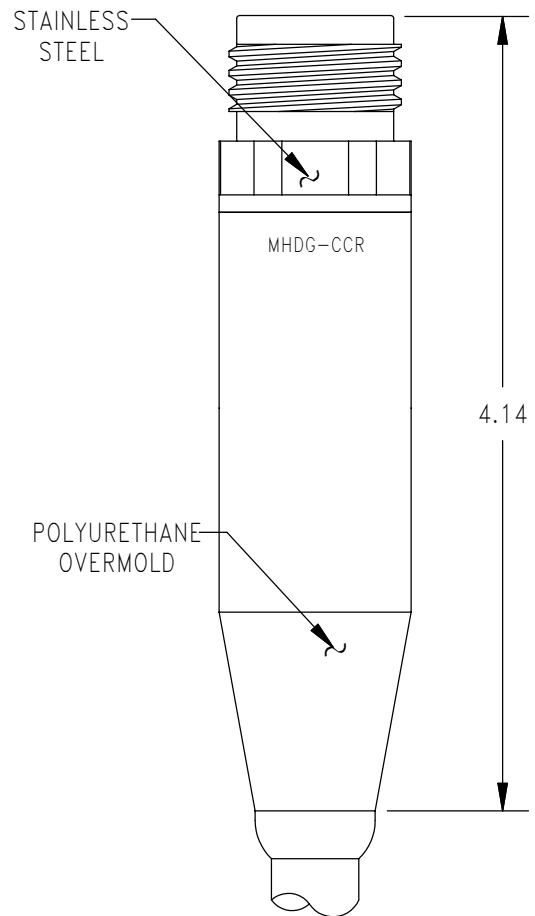
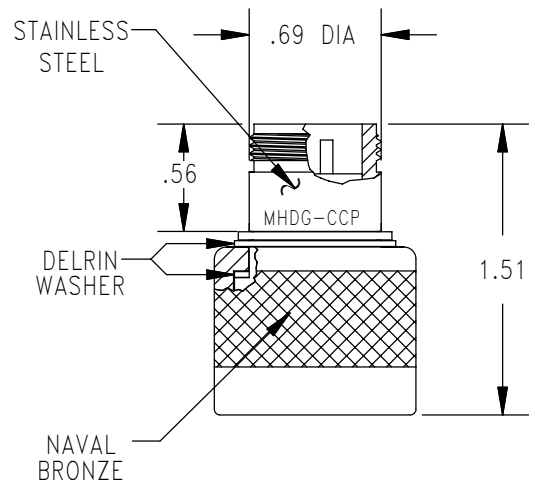
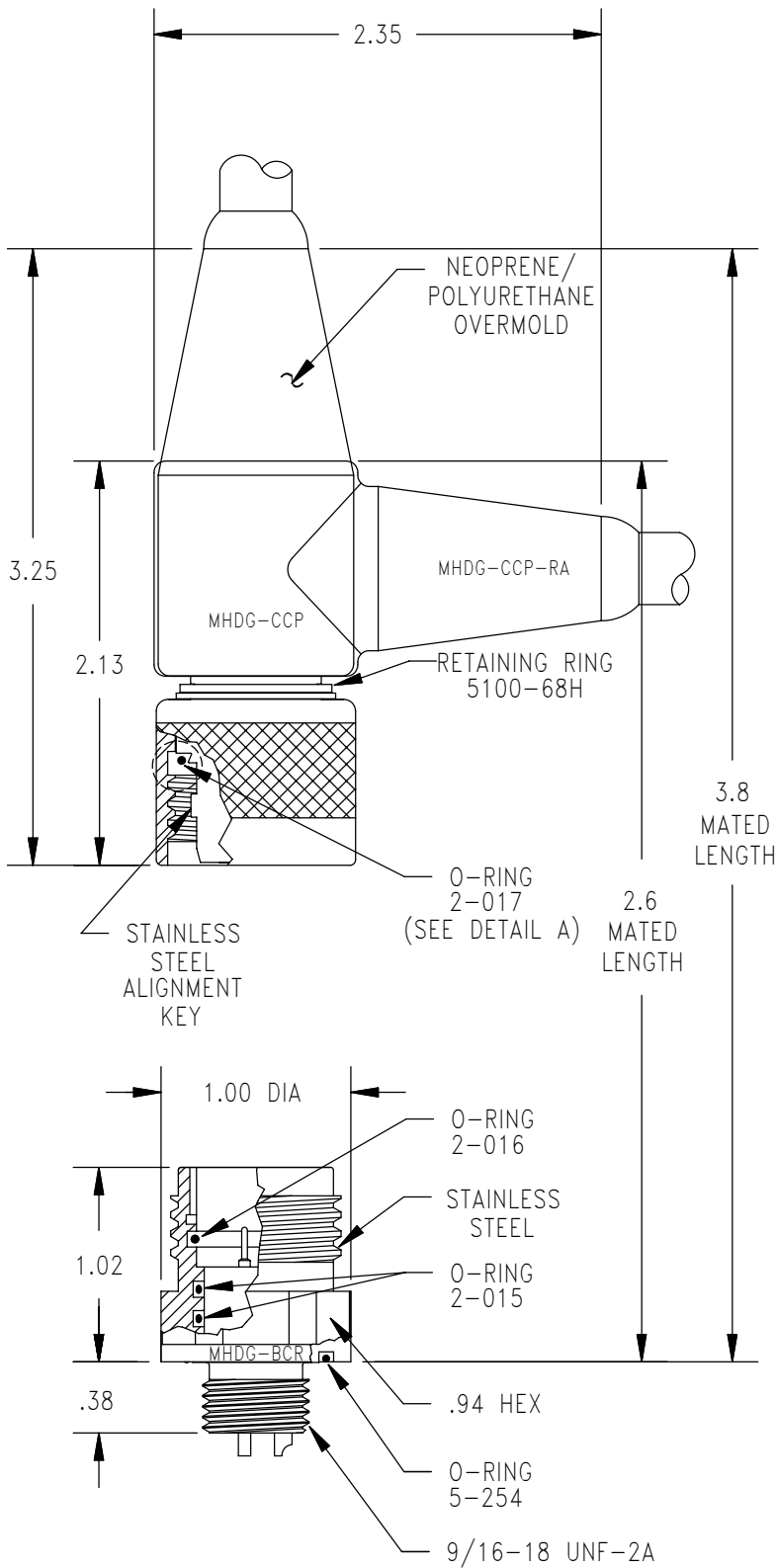

DETAIL A

CONTACT CONFIGURATION
(BCR FACE VIEW)

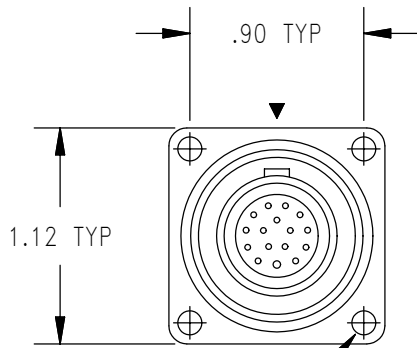

4X .125 DIA THRU

STAINLESS STEEL

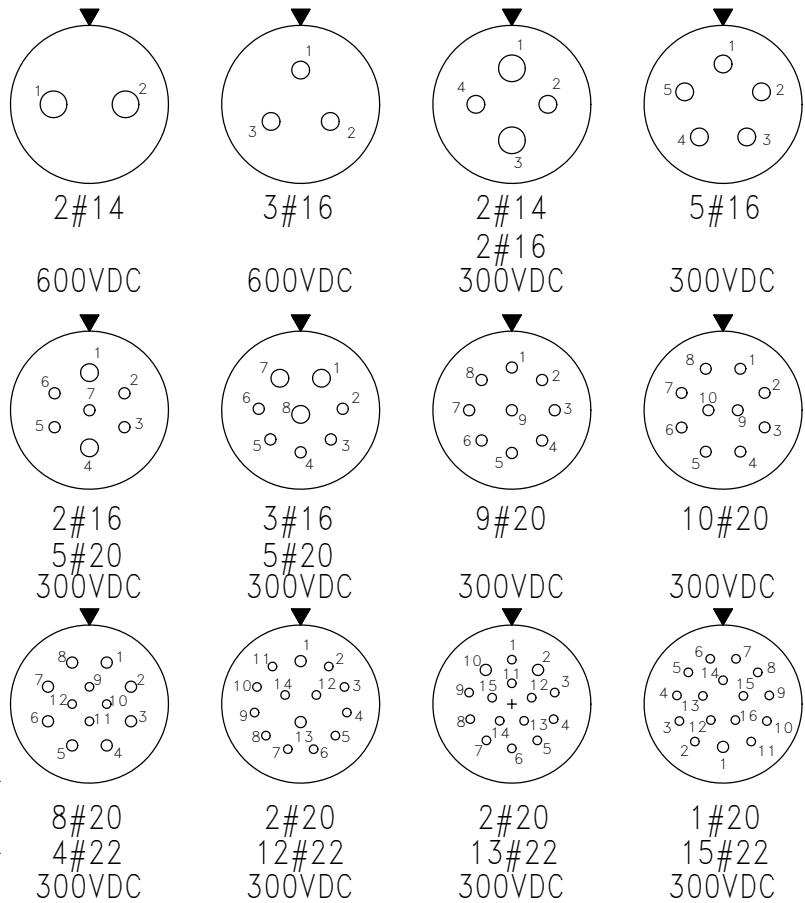
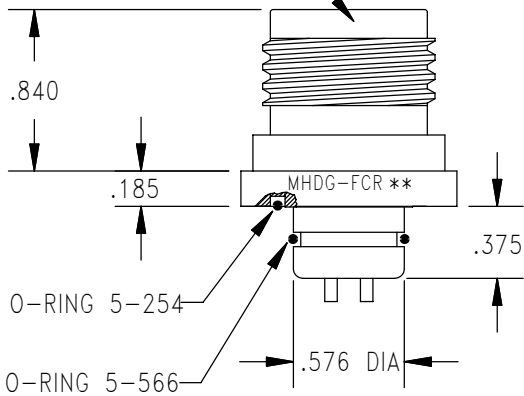

MOUNTING INSTRUCTIONS

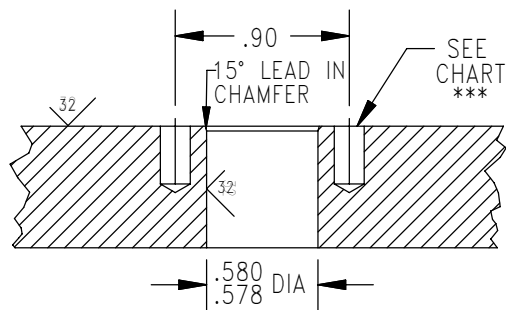

MOUNTING TORQUE FOR MHDG-BCR	not to exceed 150 in lbs	MATED PRESSURE RATING (psi)	10,000
DUMMY PLUG FOR MHDG-BCR/FCR/CCR	MHDG-SCP	DUMMY PLUG FOR MHDG-CCP	MHDG-SCR

NOTE: CCP is not terminated to cable unless specified.
 * Please specify number of contacts.
 ** Internal assembly same as MHDG-BCR (facing page).
 *** Blind tapped hole not to penetrate bulkhead, minimum full thread depth 2 times bolt diameter.
 **** Oil filled version available. See section 86.
 ***** O-Ring installation tool available - Contact factory for further details.

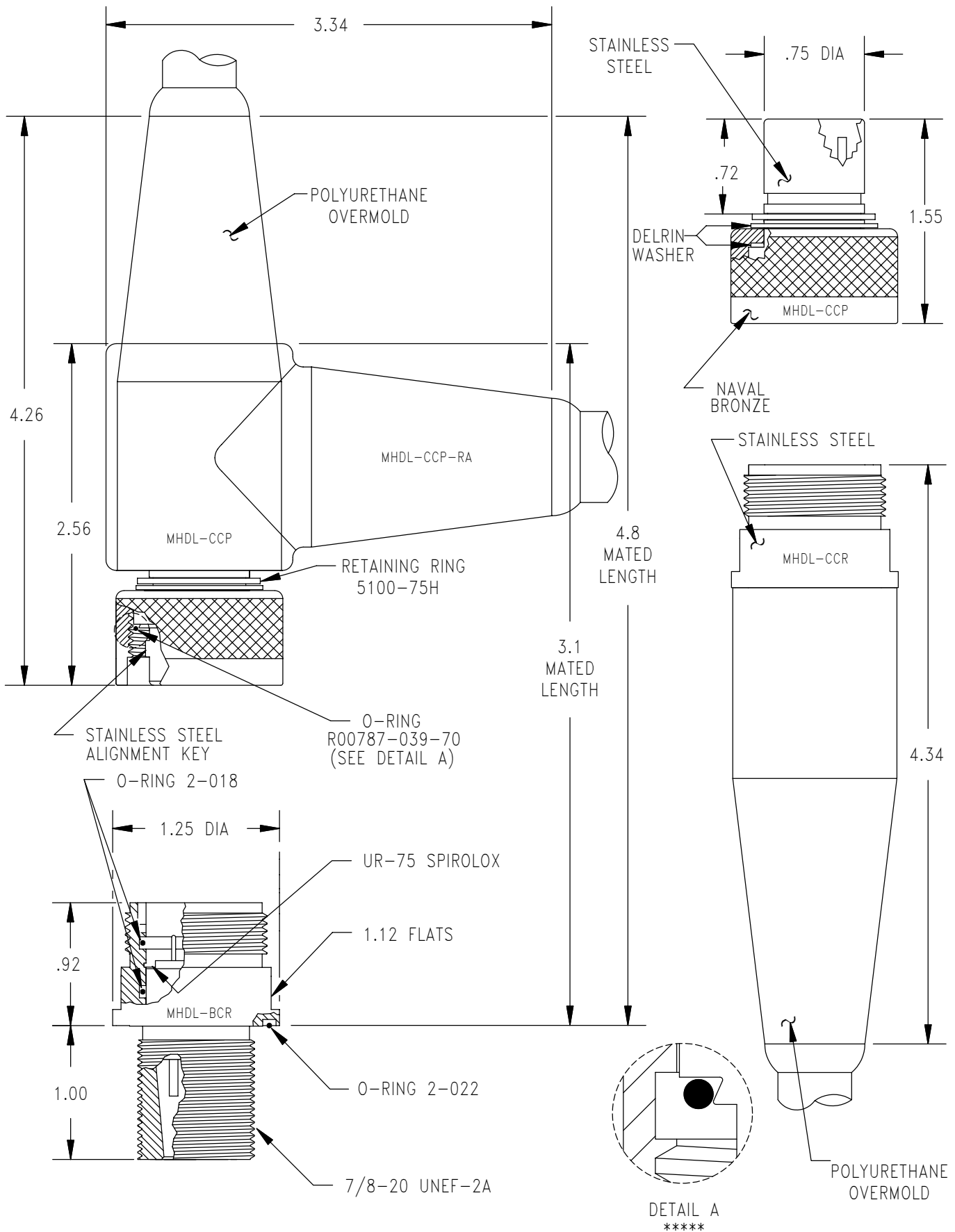

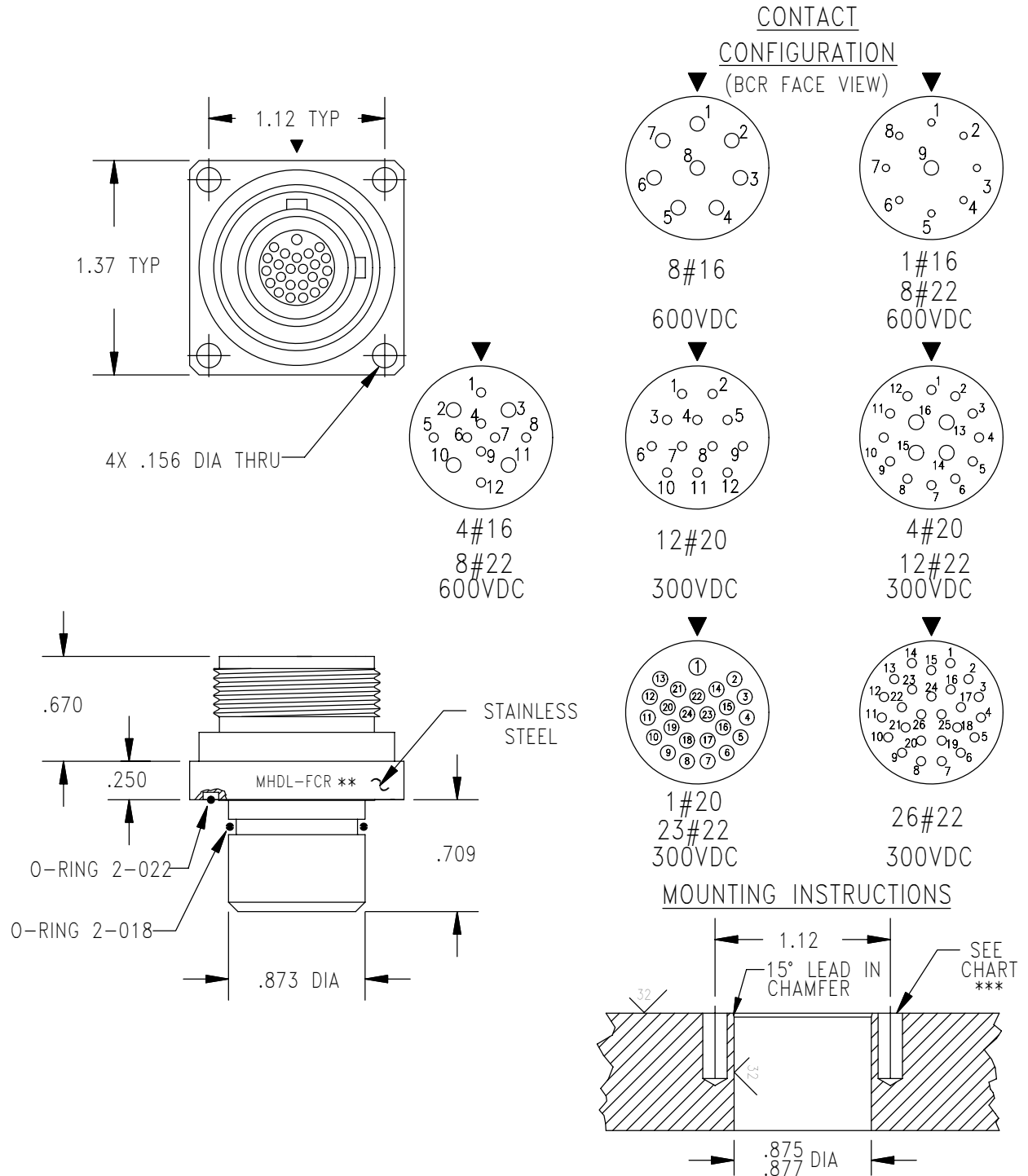

MOUNTING TORQUE FOR MHDLC-BCR	not to exceed 200 in lbs	MATED PRESSURE RATING (psi)	10,000
DUMMY PLUG FOR MHDLC-BCR/FCR/CCR	MHDLC-SCP	DUMMY PLUG FOR MHDLC-CCP	MHDLC-SCR

NOTE: CCP is not terminated to cable unless specified.
 * Please specify number of contacts.
 ** Internal assembly same as MHDLC-BCR (facing page).
 *** Blind tapped hole not to penetrate bulkhead, minimum full thread depth 2 times bolt diameter.
 **** Oil filled version available upon request. See section 86.
 ***** O-Ring installation tool available - Contact factory for further details.

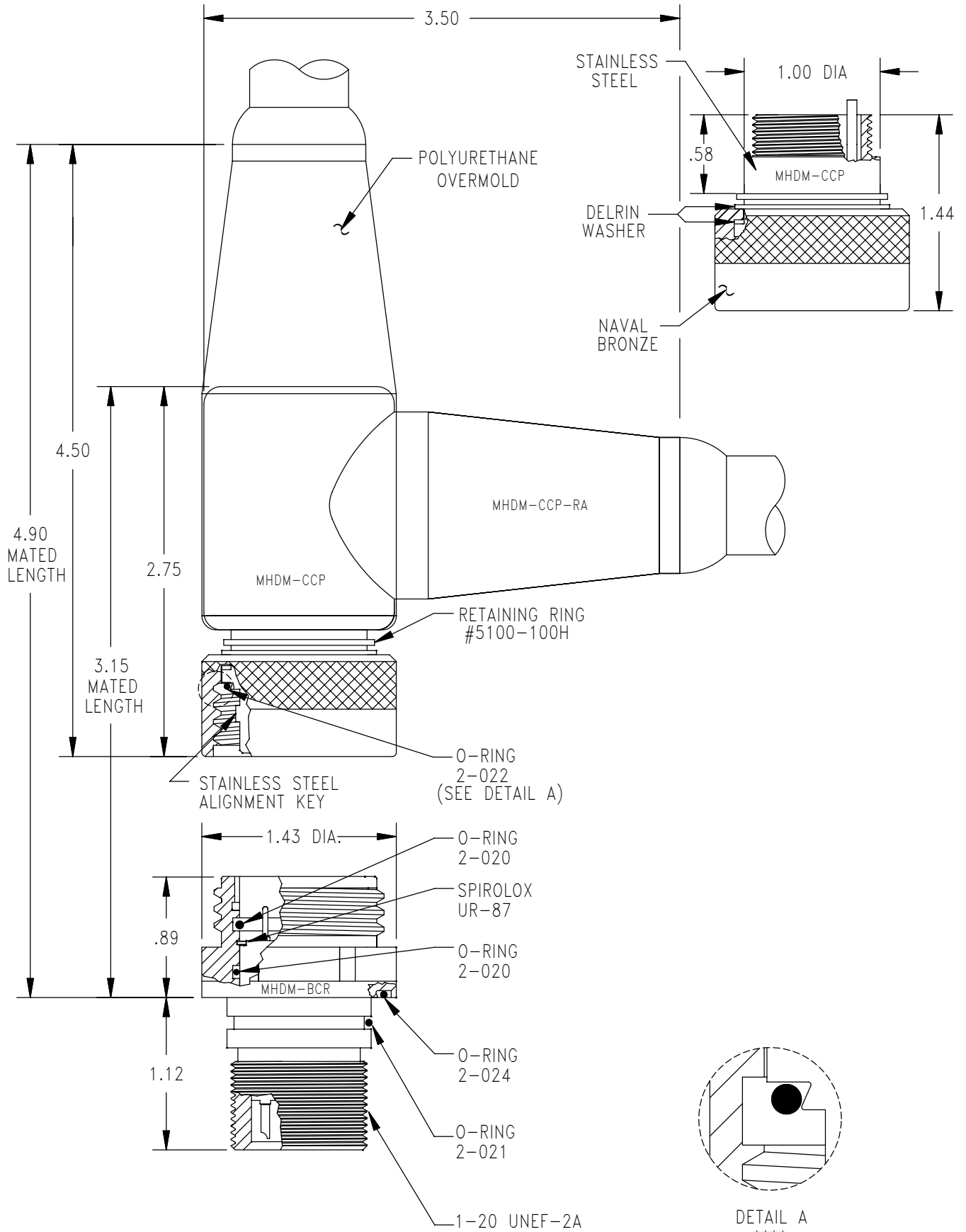

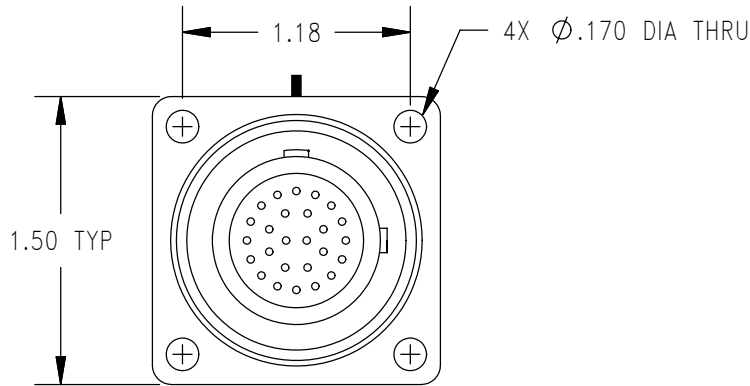

CONTACT CONFIGURATION
(BCR FACE VIEW)

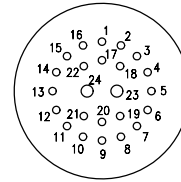

2#20
22#22
300VDC

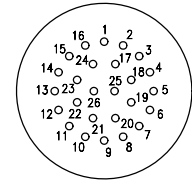

26#20
300VDC

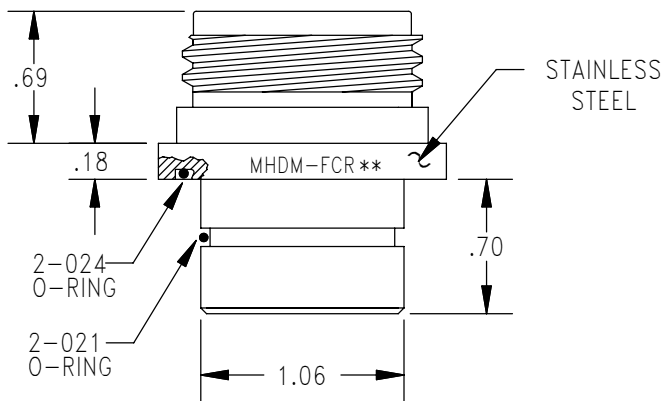

FCR
MOUNTING
INSTRUCTIONS

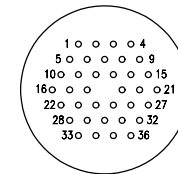

36#22
300VDC

BCR
MOUNTING
INSTRUCTIONS

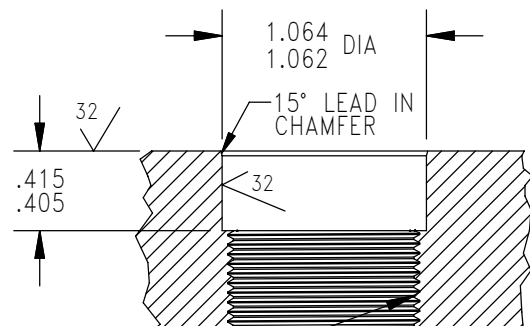
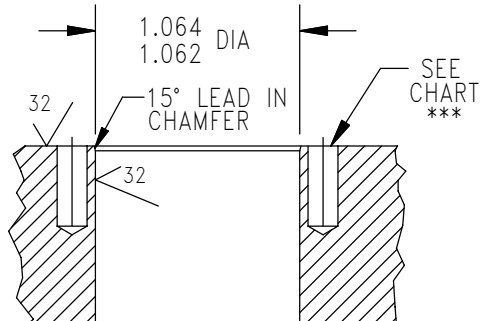

MOUNTING TORQUE FOR BCR	not to exceed 200 in lbs	MATED PRESSURE RATING (psi)	10,000
DUMMY PLUG FOR BCR	MHDM-SCP	DUMMY PLUG FOR CCP	MHDM-SCR

NOTE: CCP is not terminated to cable unless specified.
 * Please specify number of contacts.
 ** Internal assembly is the same as the MHDM-BCR (facing page).
 *** Blind tapped hole not to penetrate bulkhead, minimum full thread depth 2 times bolt diameter.
 **** O-Ring installation tool available - Contact factory for further details.

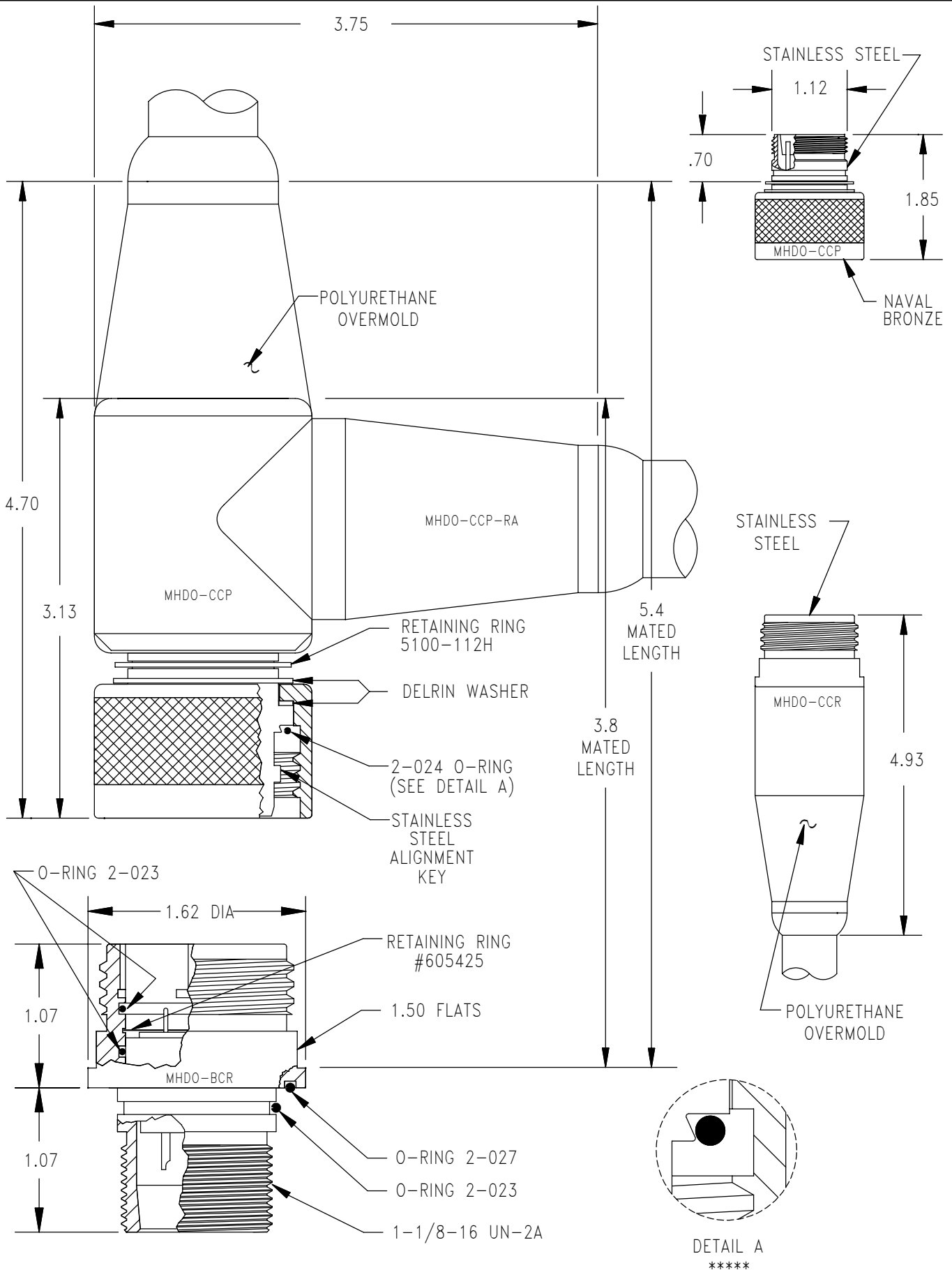

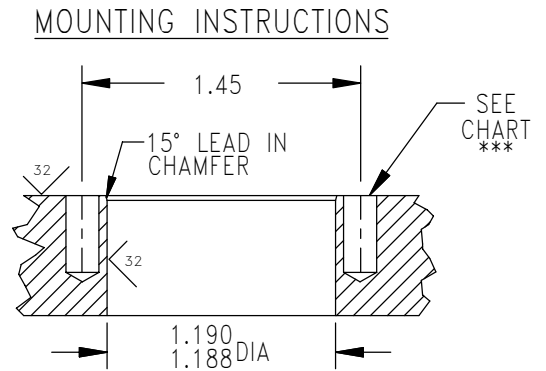
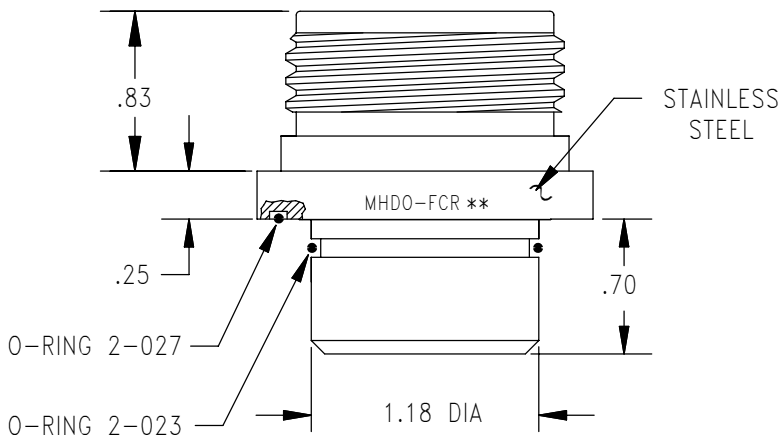
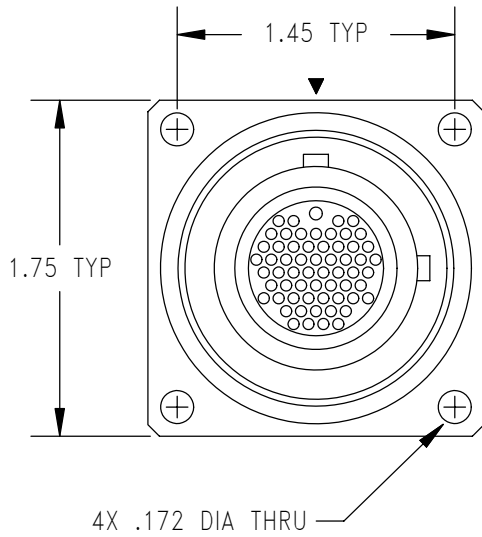

MOUNTING TORQUE FOR MHDO-BCR	not to exceed 200 in lbs	MATED PRESSURE RATING (psi)	10,000
DUMMY PLUG FOR MHDO-BCR/FCR/CCR	MHDO-SCP	DUMMY PLUG FOR MHDO-CCP	MHDO-SCR

NOTE: CCP and CCR are not terminated to cable unless specified.
 * Please specify number of contacts.
 ** Internal assembly same as MHDO-BCR (facing page).
 *** Blind tapped hole not to penetrate bulkhead, minimum full thread depth 2 times bolt diameter.
 **** Oil filled version available. See section 86.
 ***** O-Ring installation tool available – Contact factory for further details.

CONTACT
CONFIGURATION
(BCR FACE VIEW)

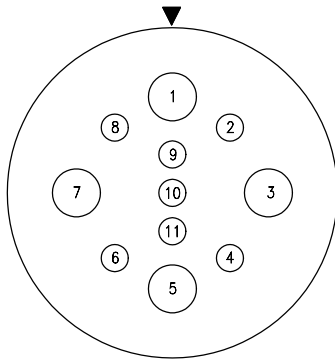

7#22
4#10
600VDC

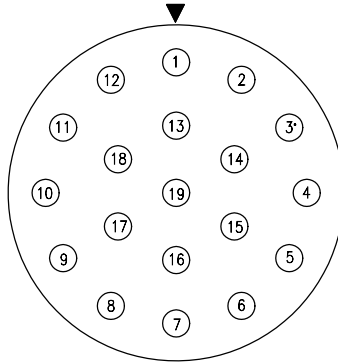

19#16
600VDC

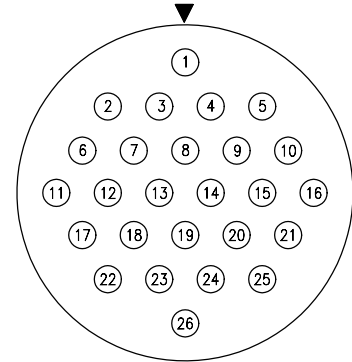

26#20
450VDC

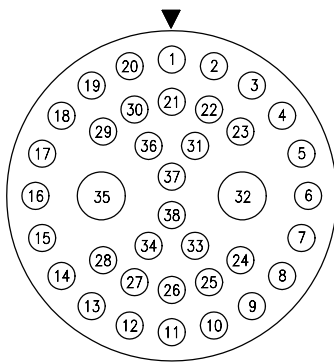

2#10
36#22
300VDC

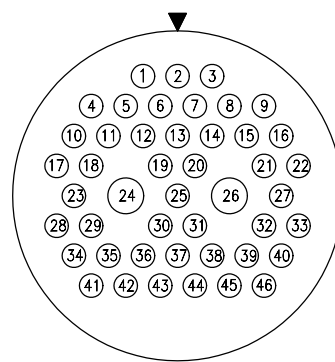

44#22
2#16
300VDC

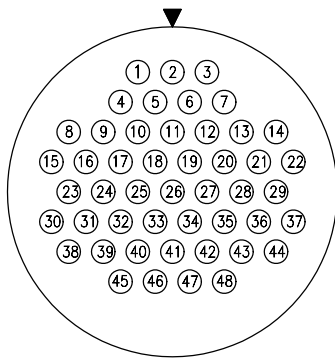

48#22
300VDC

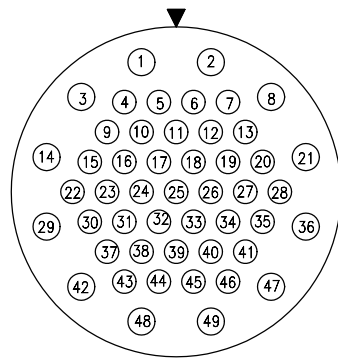

12#20
37#22
300VDC

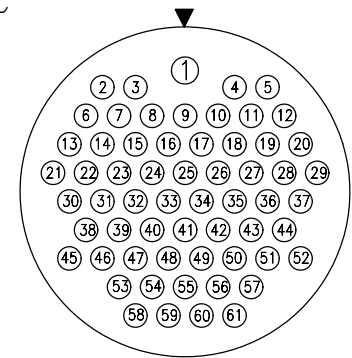

1#20
60#22
300VDC

THIS PAGE INTENTIONALLY LEFT BLANK

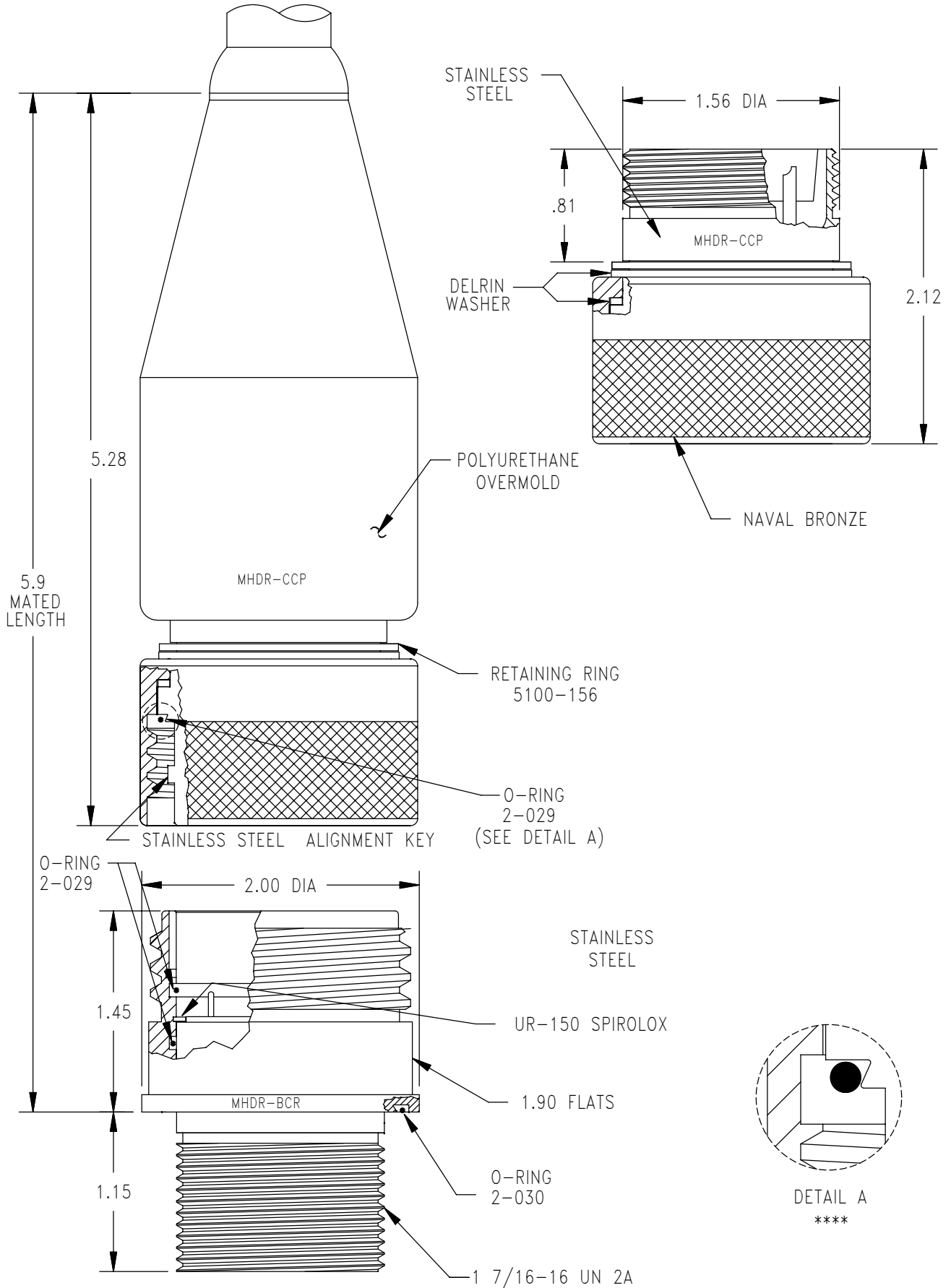

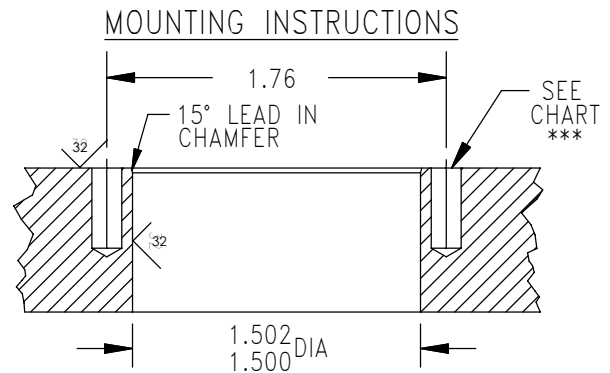
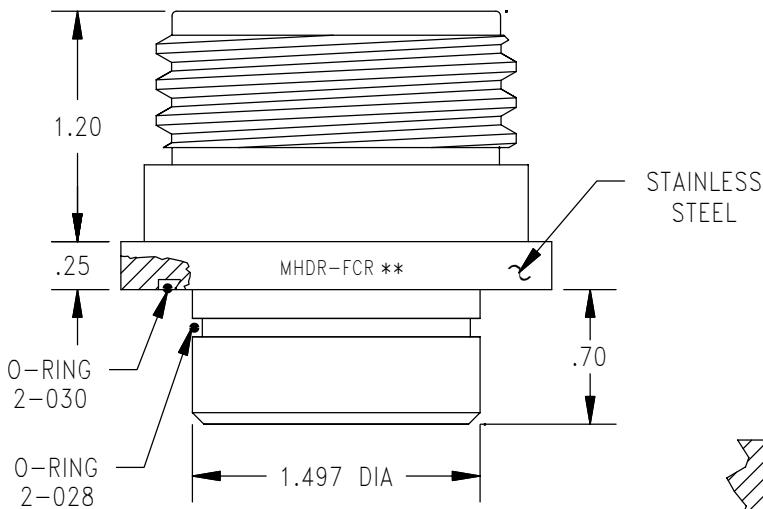
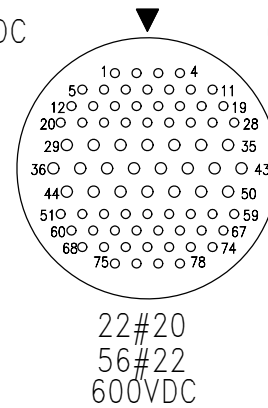
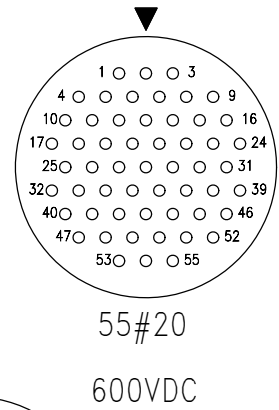
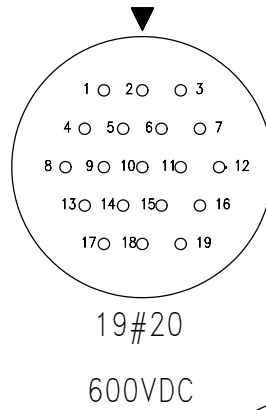
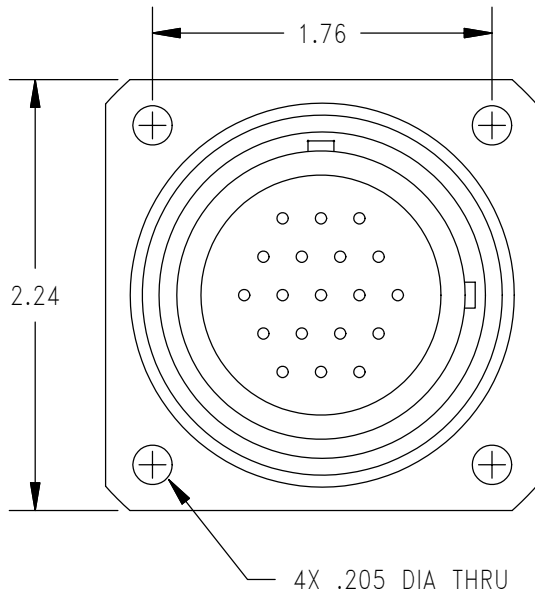

MOUNTING TORQUE FOR MHDR-BCR	not to exceed 200 in lbs	MATED PRESSURE RATING (psi)	10,000
DUMMY PLUG FOR MHDR-BCR/FCR/CCR	MHDR-SCP	DUMMY PLUG FOR MHDR-CCP	MHDR-SCR

NOTE: CCP is not terminated to cable unless specified.
 * Please specify number of contacts.
 ** Internal assembly same as MHDR-BCR (facing page).
 *** Blind tapped hole not to penetrate bulkhead, minimum full thread depth 2 times bolt diameter.
 **** O-Ring installation tool available - Contact factory for further details.

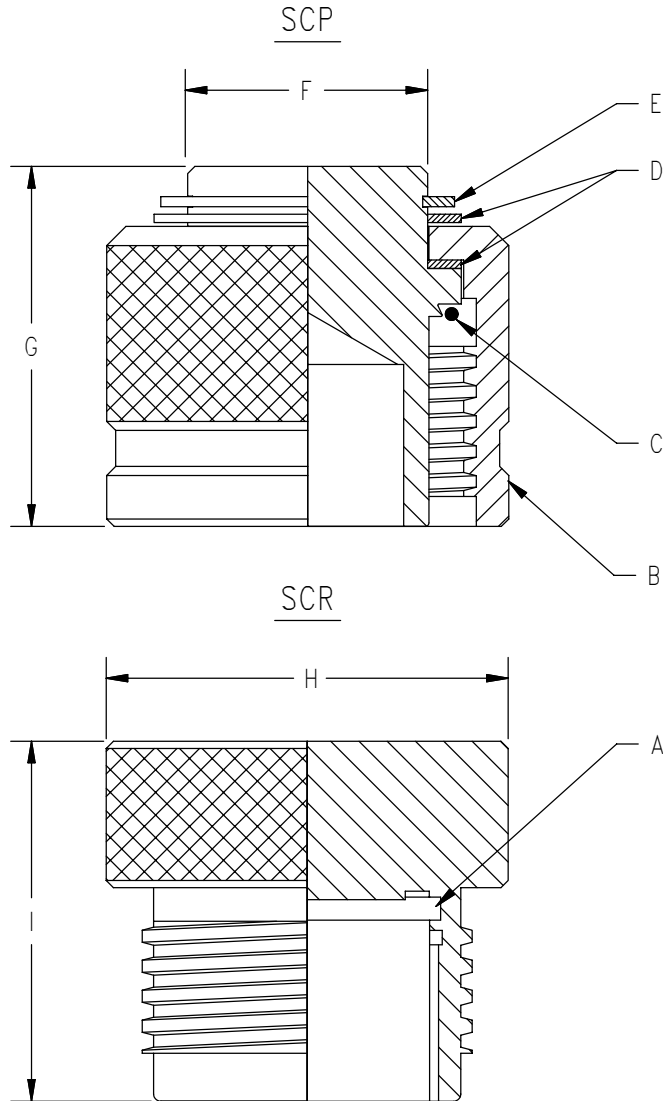

CONNECTOR SIZE	MHDG	MHDL	MHDM	MHDO	MHDR
A O-RING	2-016	2-018	2-020	2-023	2-029
B ENGAGING NUT	605165	605280	602004	605450	602261
C O-RING	2-017	R00787-039-070	2-022	2-024	2-029
D DELRIN WASHER(2X)	605101	605273	602005	605430	602220
E RETAINING RING	5100-68	5100-75	5100-100	5100-112	5100-156
F DIA	.69	.75	1.00	1.12	1.56
G	1.05	.95	.97	1.25	1.45
H DIA	1.00	1.25	1.43	1.62	2.00
I	1.00	.90	.87	1.25	1.45
MATED PRESSURE RATING (psi)	10,000	10,000	10,000	10,000	10,000