

DESCRIPTION AND MATERIAL	<ul style="list-style-type: none"> • Body and engaging nut are 316 Stainless Steel, passivated per QQ-P-35 Type VI. • To 10,000 PSI in mated condition. • Bulkhead connector design open face pressure rated to 5000 PSI. • Contacts gold plated per MIL-G-45204. • Engaging nuts have Acme threads for rugged applications and for quick connection (shell size 15 has standard V thread). • Working voltage – 850 VDC (contact factory for high voltage applications).
CABLE	<ul style="list-style-type: none"> • CCP, CCP-R/A and CCR are molded on standard 24” length of 16 AWG SO cable. IE55-1508 is molded on a standard 24” length of 18 AWG SO cable. • Other cable options available at customer’s request. • BCR/FCR have 48” teflon leads, Type E per MIL 16878/4 16 AWG. • Un-Terminated versions of CCP available.
USES	<ul style="list-style-type: none"> • Heavy Duty applications. • Hazardous environment. • Power Transmission. • Signal Telemetry. • ROV applications.
GUIDELINES	<ul style="list-style-type: none"> • All mounting and sealing surfaces require a 32 finish. • Lubricate mating surfaces with 3M Silicone Spray or equivalent, DO NOT GREASE! Connectors must be lubricated on a regular basis. • Lubricate o-rings with Dow Corning #111 Valve Lubricant or equivalent. • Use Dust Caps and keep connectors clean to prevent damage in storage and service. • Keep o-ring grooves clean and avoid cuts, nicks and tears on rubber surfaces. • Elastomers can be seriously degraded if exposed to direct sunlight or high ozone levels for extended periods of time. • Clean plugs and receptacles with soap and fresh water. Rinse out with alcohol, allowing connector to air dry. • Replace o-rings when re-using connectors.
NOTE	<ul style="list-style-type: none"> • Also available as inverted series, see following section.
Specifications for: SUBMINIATURE CONNECTOR (Bulletin 70 03/06)	<ul style="list-style-type: none"> • Body and engaging nut are 6AL-4V Titanium. Engaging nut is Tiodized[®] per AMS 2488 TYPE II. • Working voltage – 300 VDC. • IE55-1204/06-CCP, CCP-R/A and CCR are molded on standard 24” 22 AWG polyurethane jacketed cable. IE55W-1002/03-CCP, CCP-R/A and CCR are molded on standard 24” 20 AWG Belden cable. • IE55-1204/06-BCR are molded on standard 6” Teflon lead, Type E per MIL16878/4, 24 AWG. IE55W-1002/03-BCR are molded on standard 6” Teflon lead, Type E per MIL 16878/4, 22 AWG. • Mainly used on small sensor packages. • Light duty applications only.

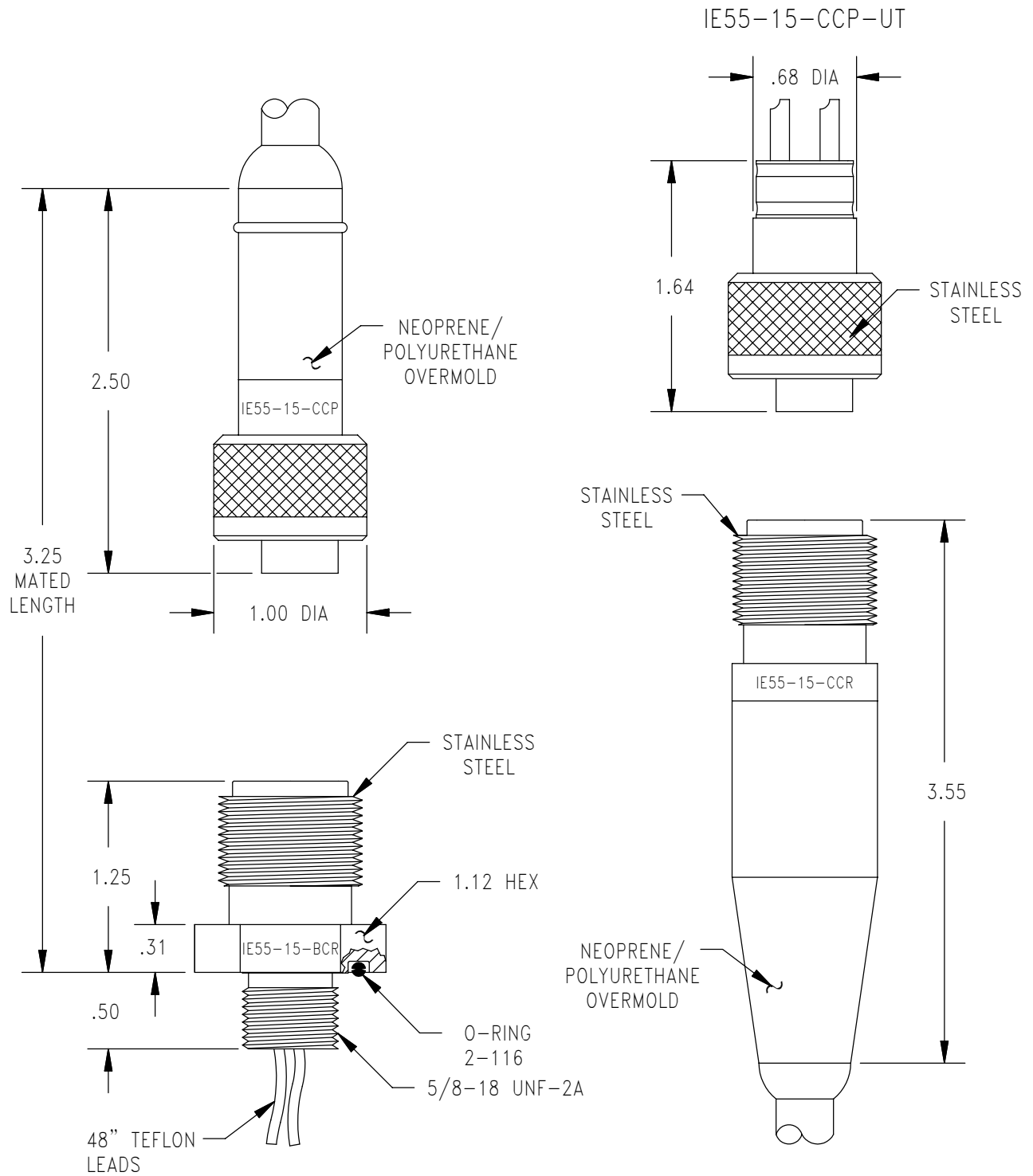

IE55-15

IE55 RUBBER MOLDED METAL SHELL SERIES

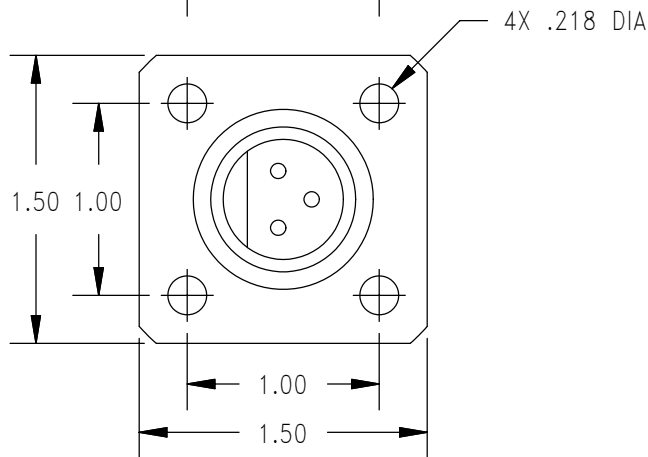
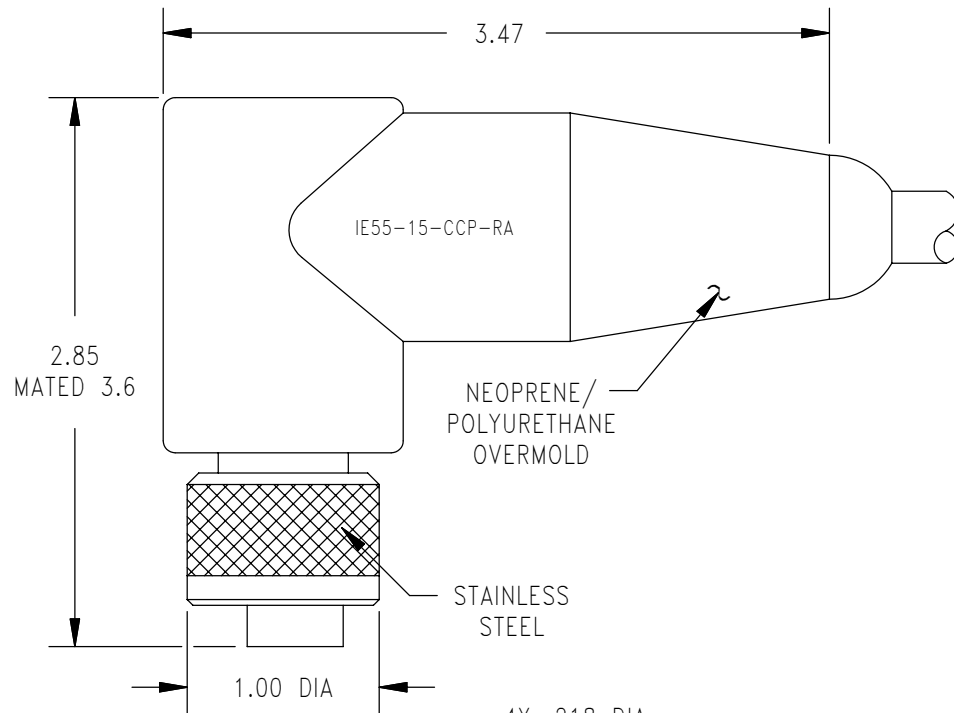

CONTACT CONFIGURATION (BCR FACE VIEWS)

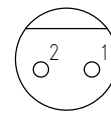

2#14

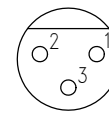

3#14

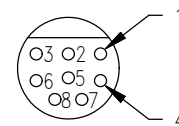

8#16

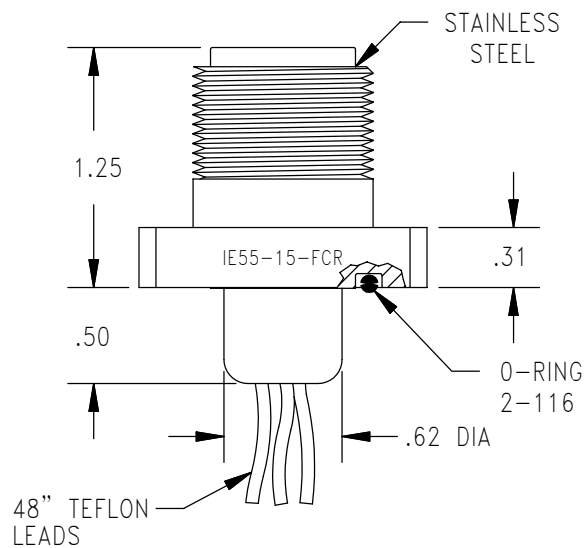

MATED PRESSURE RATING (psi)	10,000
MOUNTING TORQUE FOR BCR	not to exceed 125 in lbs
DUMMY PLUG FOR BCR, FCR, CCR	IE55-15*-SCP
DUMMY PLUG FOR CCP	IE55-15*-SCR
* Specify number of contacts.	