

DESCRIPTION AND MATERIAL	<ul style="list-style-type: none"> • 316 stainless steel body passivated per QQ-P-35 Type VI. • Optional body is 6061-T6 aluminum, hard anodized per MIL-A-8625, Type III, Class 2. • Metal body waterblocked with glass reinforced epoxy insert and neoprene or polyurethane overmolded. • One to 26 conductors depending on gauge of conductors. • Up to 600 VDC. • Up to 10,000 PSI.
MATING	<ul style="list-style-type: none"> • This penetrator is threaded at one end with wire leads coming through the thread hole. The opposite end away from the penetrator can be terminated to a rubber, epoxy or metal shell connector. See applicable sections of catalogue for details.
CABLE	<ul style="list-style-type: none"> • Penetrators have 12" teflon leads, Type E per MIL 16878/4 18 AWG. • The penetrator's amperage and voltage may be limited by amperage and voltage ratings of the cable to which the penetrator is molded.
USES	<ul style="list-style-type: none"> • Light to medium duty applications. • Hazardous environment. • Power transmission. • Signal telemetry. • Keeps mating and unmating manipulation away from bulkhead. • Allows greater flexibility in mating cable away from bulkhead. • Waterblocked insert keeps bulkhead from flooding if accidental cable damage occurs. • Very low right angle profile.
GUIDELINES	<ul style="list-style-type: none"> • May be threaded into bulkhead or fastened by use of a nut and washer. • All mounting surfaces require a 32 finish. • Keep o-ring grooves clean. • Avoid o-ring cuts and nicks. • Lubricate o-rings with Dow Corning #111 Valve Lubricant or equivalent. • Replace o-rings when re-using connectors. • Avoid contact with noxious solvents. • Elastomers can be seriously degraded if exposed to direct sunlight or high ozone levels for extended periods of time.

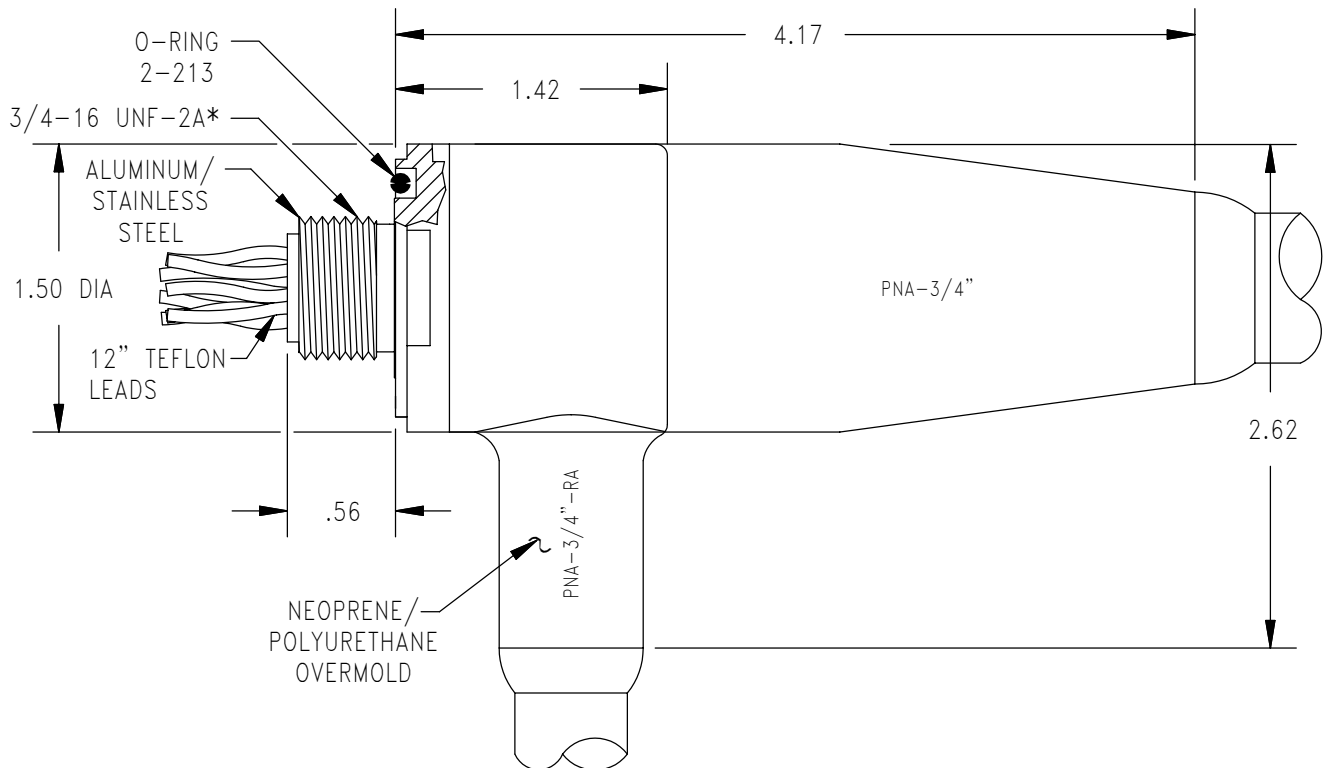

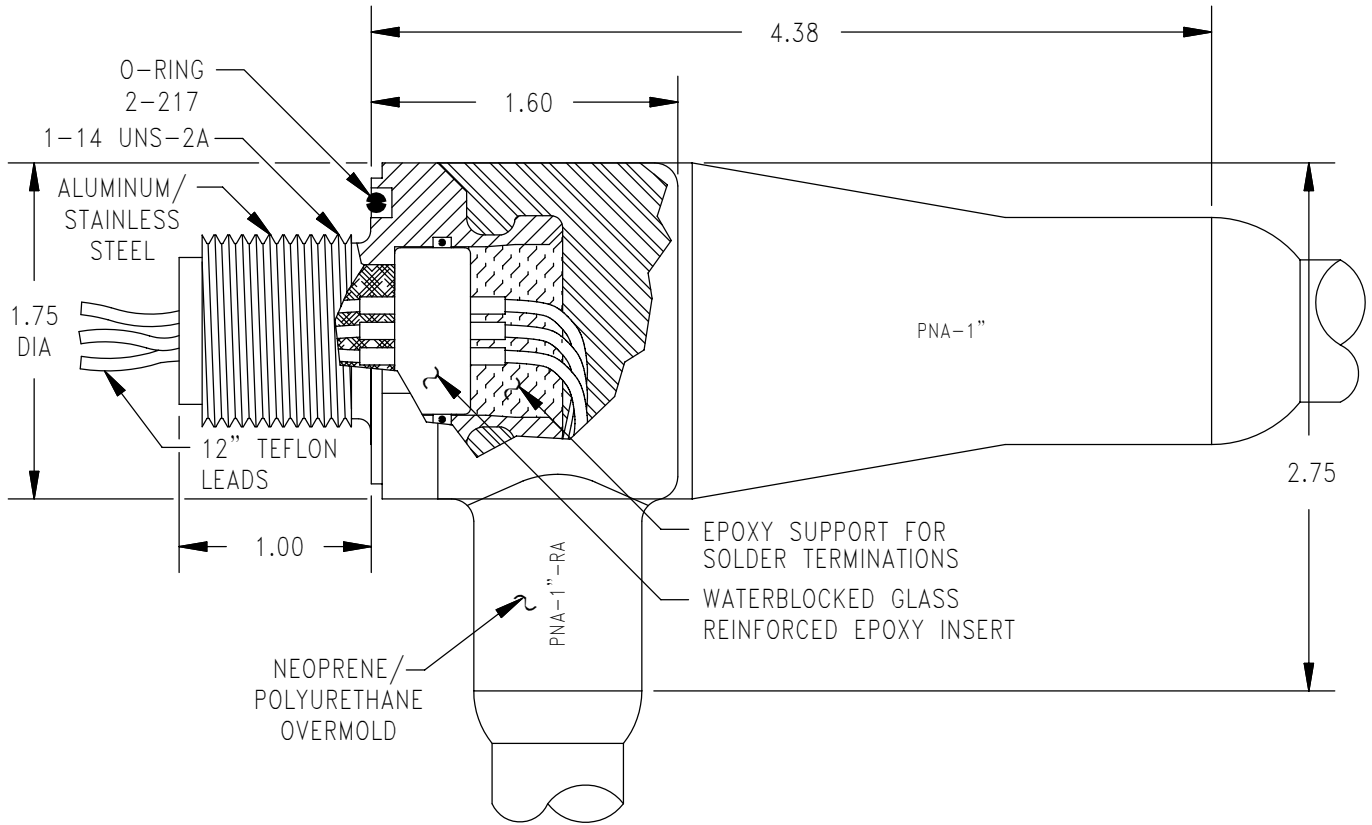
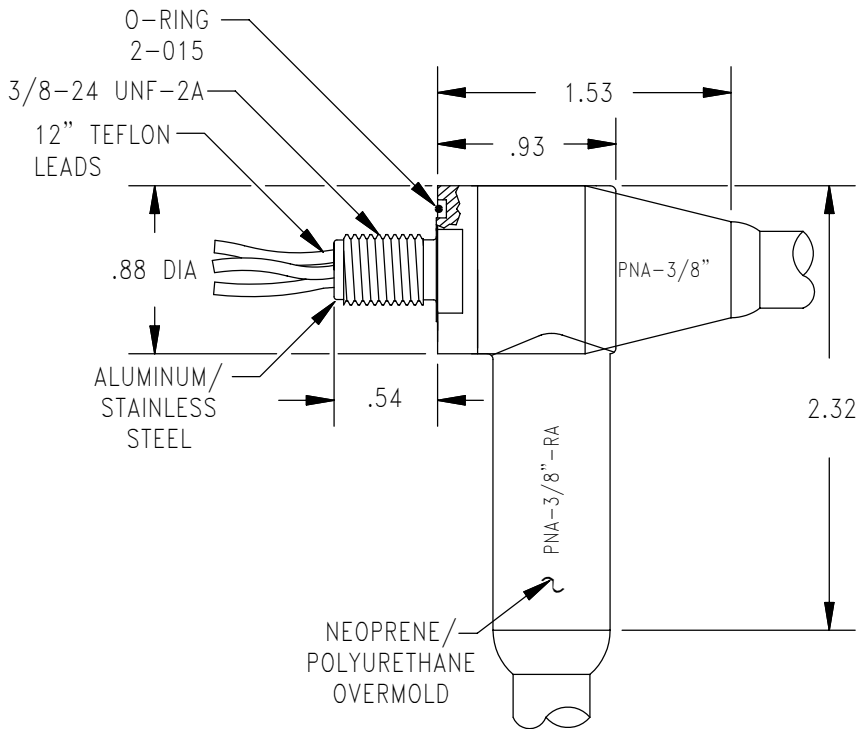
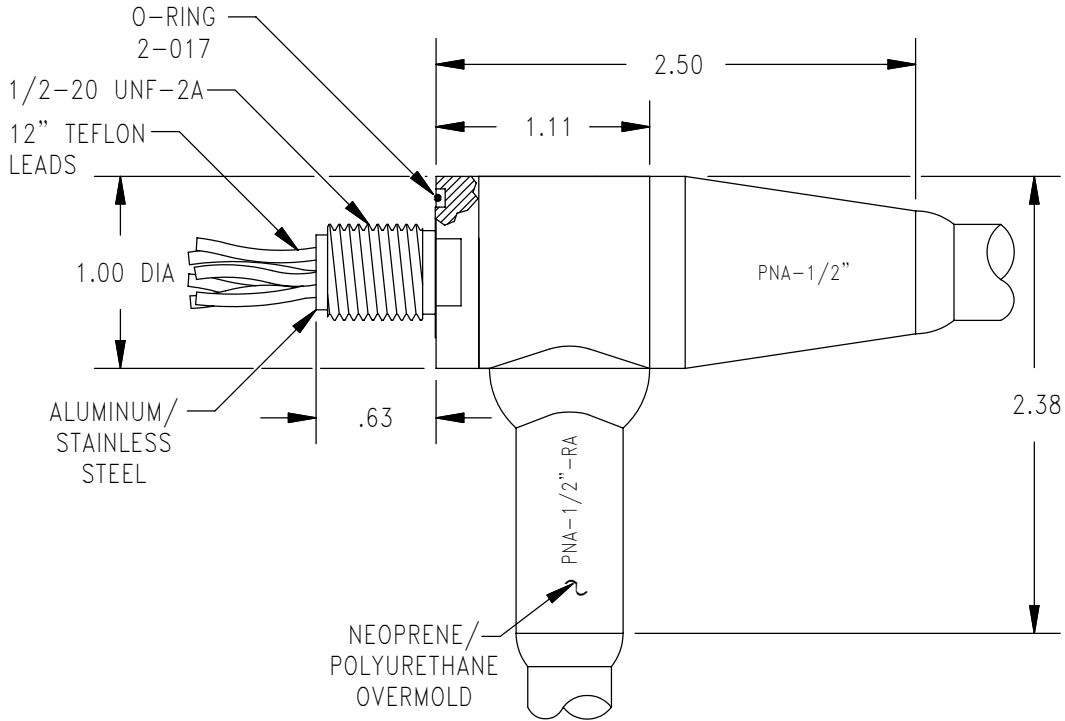

PNA SIZE	MOUNTING TORQUE FOR SS PNA (in lbs)	MOUNTING TORQUE FOR ALUMINUM PNA (in lbs)	PRESSURE RATING (psi)	MAXIMUM # OF CONTACTS
1"	200	150	10,000	26
3/4"	150	100	10,000	8
1/2"	125	80	10,000	9
3/8"	100	70	10,000	3(ALUM)/4(SS)

* Optional 5/8-18 UNF-2A stainless steel body available.

* Waterblocked glass reinforced epoxy insert available as separate item.