

- DESCRIPTION AND MATERIAL
- Identical to XS- RM connectors except sockets replace pins.
  - Molded neoprene or polyurethane (for G- size) inline connectors and glass reinforced epoxy, stainless steel or aluminum bulkhead connectors.
  - One to twelve contacts.
  - Up to 600 VDC (For higher voltages, contact factory).
  - Up to 10,000 PSI in mated condition.
  - Bulkhead connector design open face pressure rated to 5000 psi.
  - Contacts gold plated per MIL- G- 45204.
  - Field installable connectors with locking sleeve available.
  - Field installable connectors have a removable tapered boot for easy access to solder pots during field installation.
- CABLE
- Connector's amperage and voltage may be limited by amperage and voltage rating of cable to which connector is molded.
  - Inline connectors in this series, except field installables, are provided on a standard 24" length of 18 AWG SO cable unless otherwise specified. (Note: VMA provided on 24" length of 20 AWG.)
- USES
- Light to medium duty applications.
  - Hazardous environment.
  - Power transmission.
  - Signal telemetry.
  - FIB - Field installable applications.
- GUIDELINES
- All mounting surfaces require a 32 finish.
  - Accomplish mating with minimum twisting and flexing.
  - Align indexes.
  - Because sockets replace pins in this series, there is less damage potential in unplugged conditions.
  - FS can trap water (suggest flush with alcohol and blow dry).
  - Lubricate MP mating side with 3M Silicone Spray or Dow Corning #111 Valve Lubricant or equivalent.
  - Lubricate o- rings with Dow Corning #111 Valve Lubricant or equivalent.
  - Avoid o- ring cuts and nicks.
  - Replace o- rings when re- using connectors.
  - Avoid contact with noxious solvents.
  - Elastomers can be seriously degraded if exposed to direct sunlight or high ozone levels for extended periods of time.

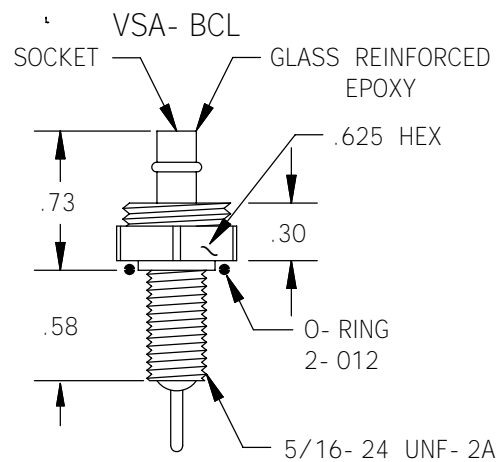

MOUNTING INSTRUCTIONS VSA-BC

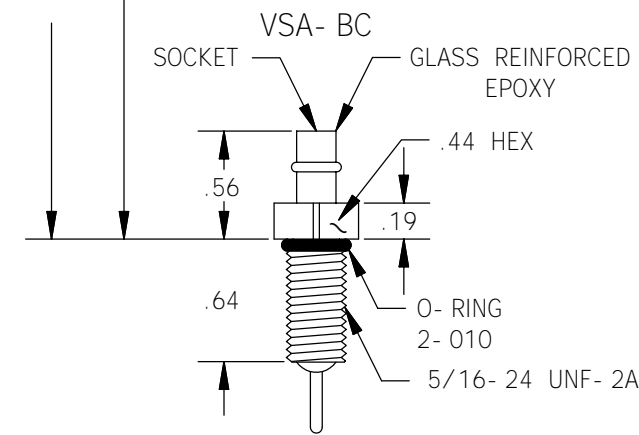
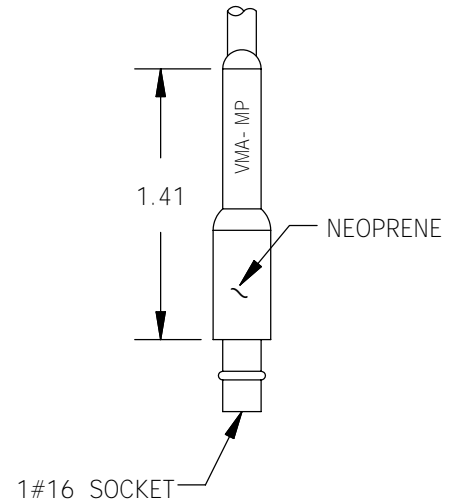
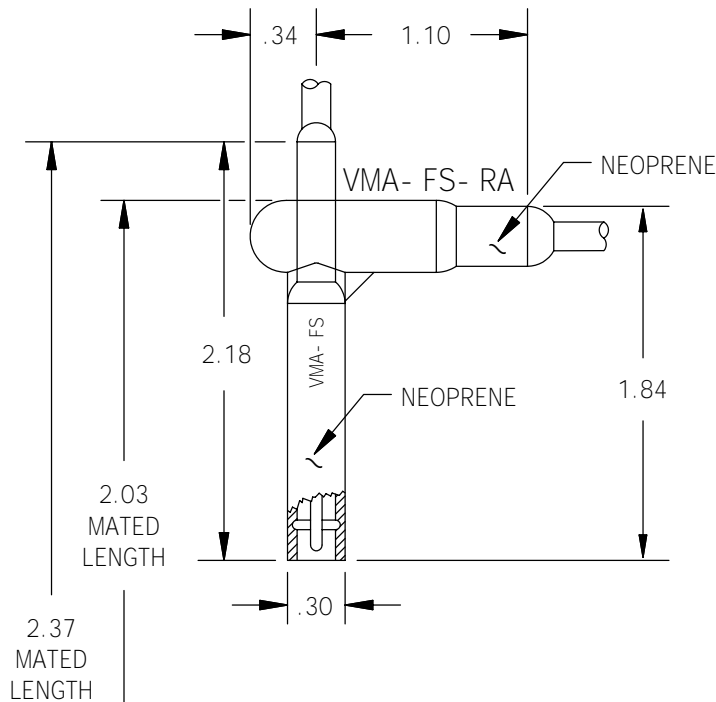
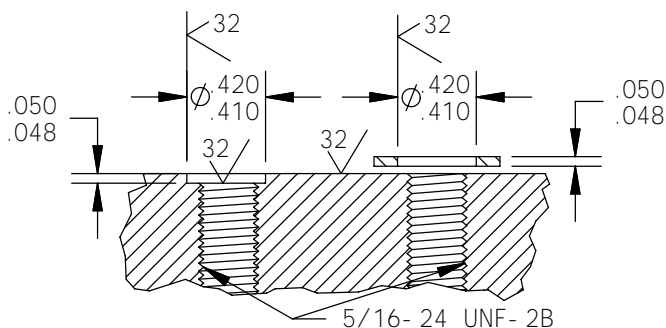

MOUNTING INSTRUCTIONS VSA-BCL

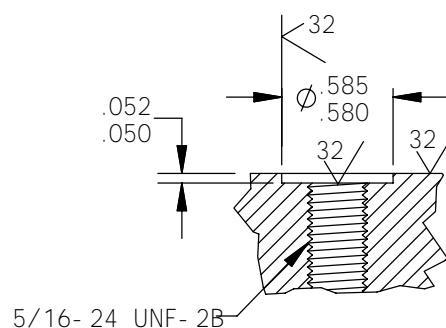

VMA- FS W/LOCKING SLEEVE

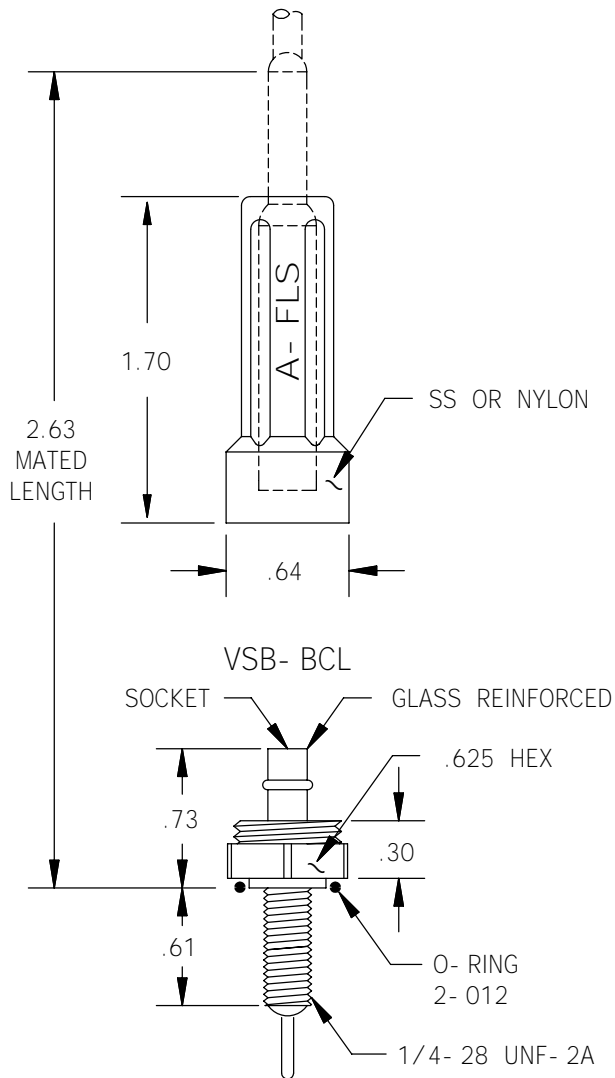

SLIP ON SERIES

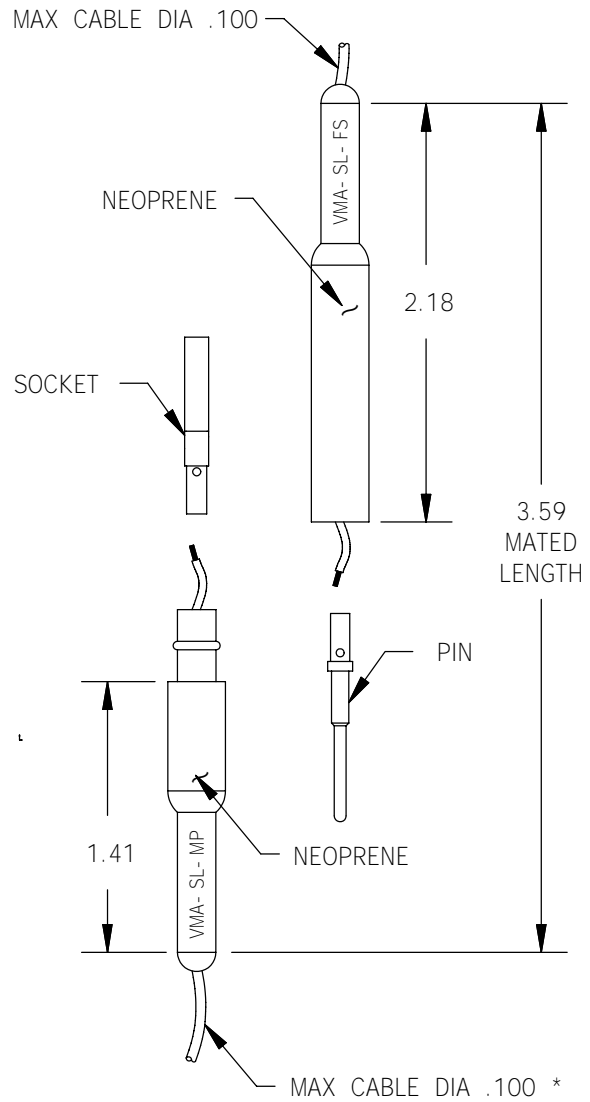

MOUNTING TORQUE FOR VSA- BC	not to exceed 5 in lbs	MOUNTING TORQUE FOR VSA- BCL	not to exceed 8 in lbs
MOUNTING TORQUE FOR VSB- BCL	not to exceed 6 in lbs	MATED PRESSURE RATING (psi)	10,000
DUMMY PLUG FOR VSA- BC, VSA- BCL, VSB- BCL, VMA- MP		DUMMY PLUG FOR VMA- FS	
LOW PRESSURE < 4,000 psi	VMA- FSD- LP	VMA- MPD	
HIGH PRESSURE > 4,000 psi	VMA- FSD- HP		
NOTE: Locking sleeves available in plastic or stainless steel, see Tech. Bulletin 25 50. * Must specify conductor diameter when ordering slip on series.			

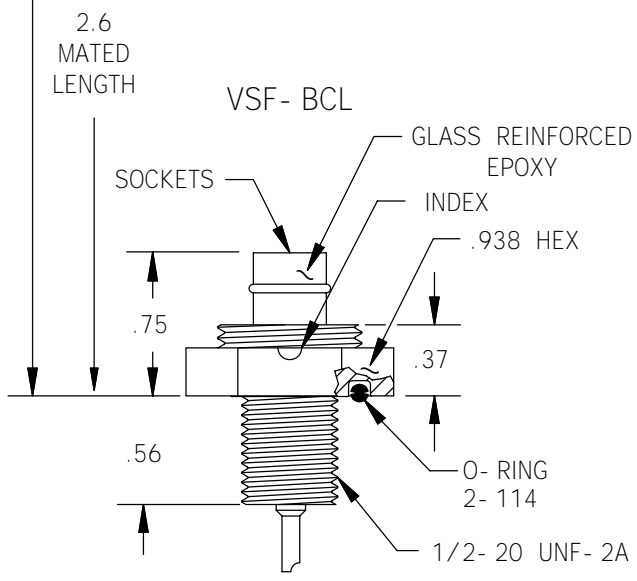
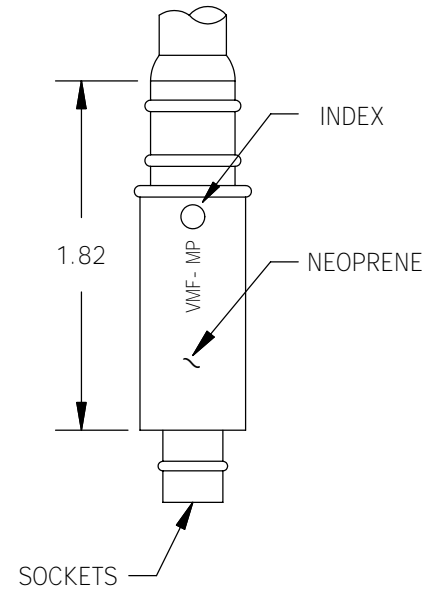
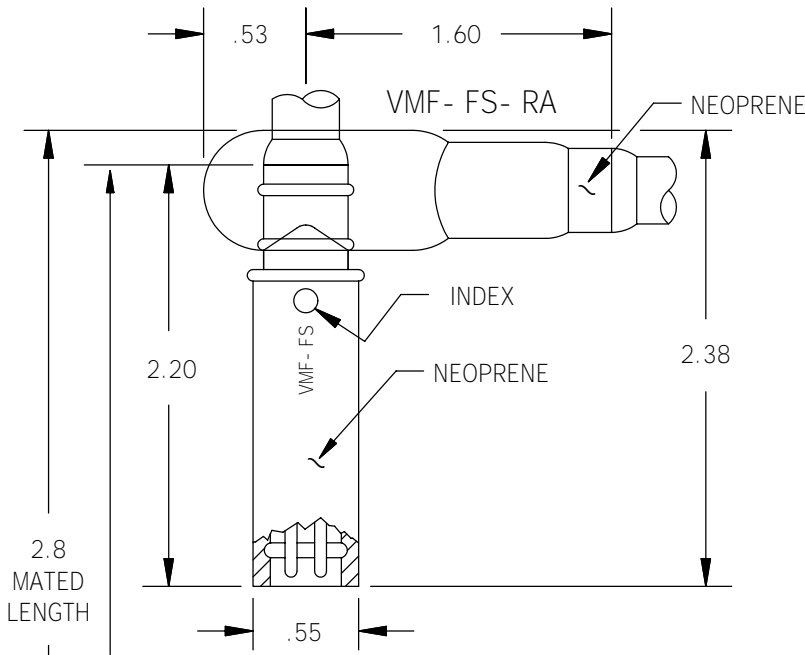

CONTACT CONFIGURATION  
(BCL FACE VIEWS)

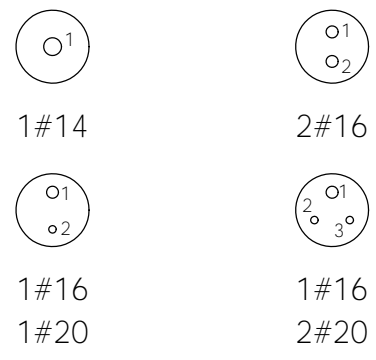

MOUNTING TORQUE FOR BCL	not to exceed 15 in lbs	MATED PRESSURE RATING (psi)	10,000
DUMMY PLUG FOR VSF- BCL, VMF- MP		DUMMY PLUG FOR VMF- FS	
LOW PRESSURE < 4,000 psi	VMF- FSD- LP	VMF- *- MPD	
HIGH PRESSURE > 4,000 psi	VMF- *- FSD- HP		
NOTE: Locking sleeves available in plastic, see Technical Bulletin 25 50. * Please specify number of contacts.			

**THIS PAGE INTENTIONALLY LEFT BLANK**

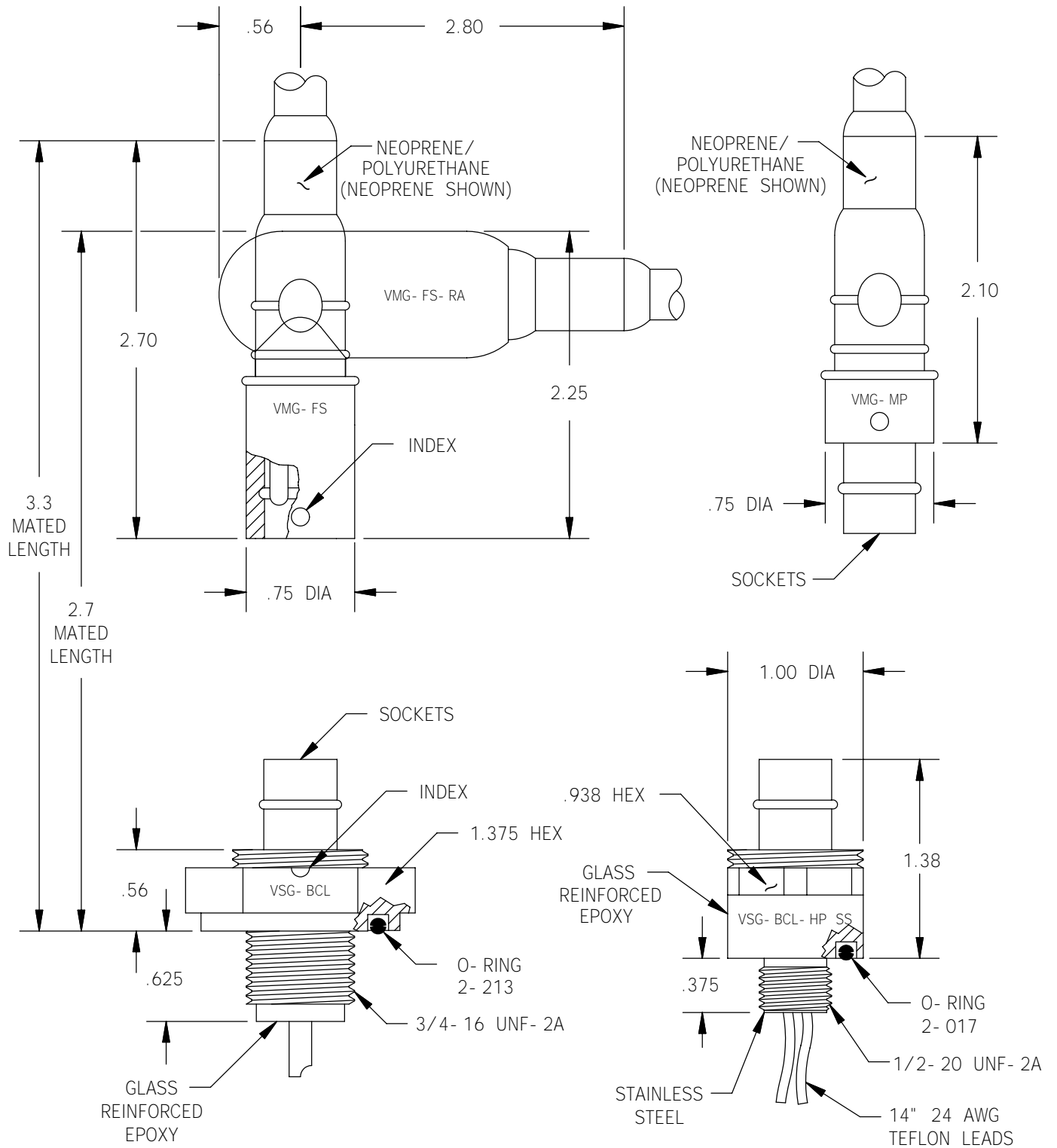

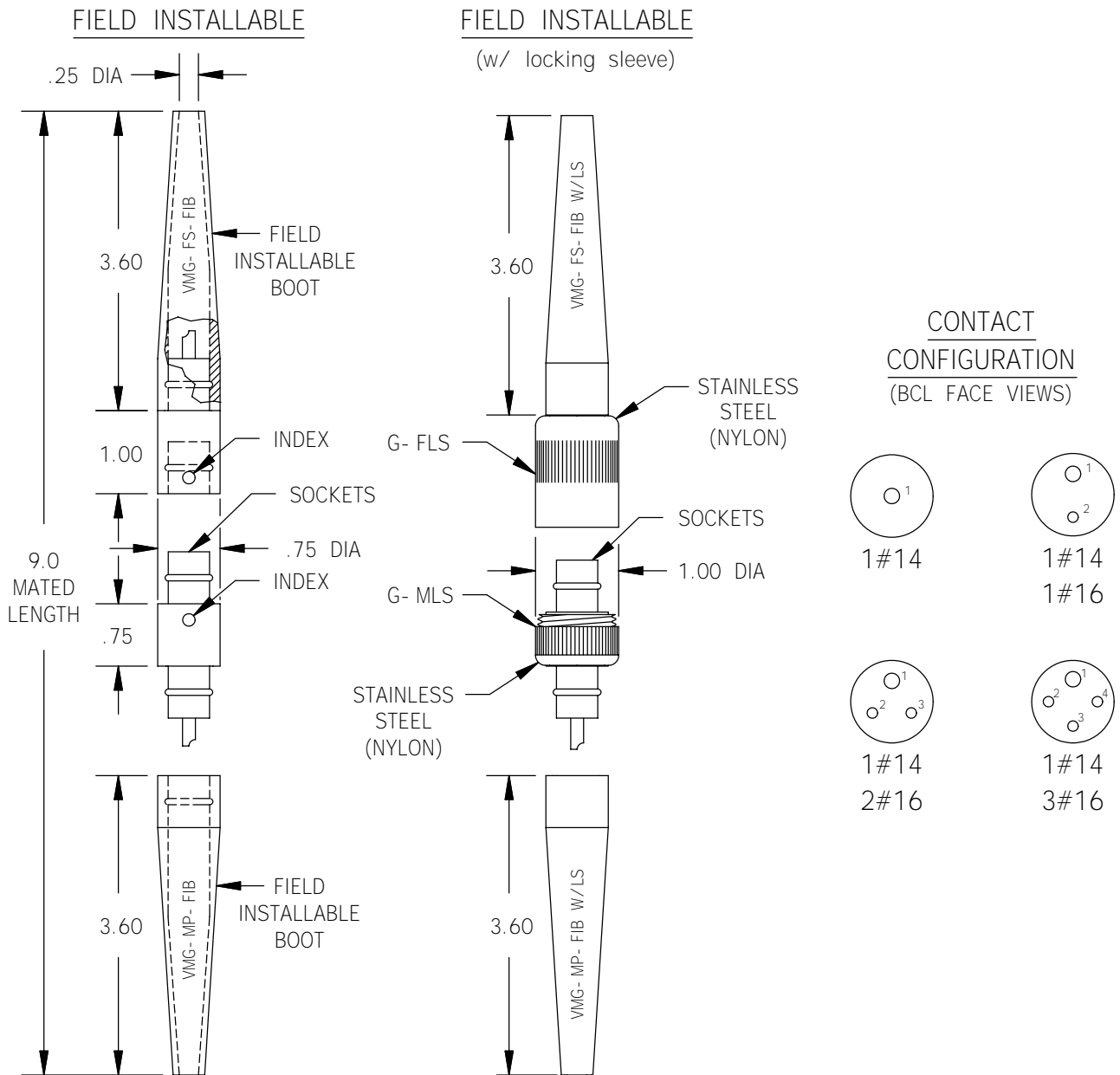

MOUNTING TORQUE FOR VSG- BCL	not to exceed 70 in lbs	MATED PRESSURE RATING (psi) FOR VSG- BCL	10,000
DUMMY PLUG FOR VSG- BCL/BCL HP SS/PBC/PBCL/PBCLM, VMG- MP		DUMMY PLUG FOR VMG- FS	
LOW PRESSURE < 4,000 psi	VMG- FSD- LP	VMG- *- MPD	
HIGH PRESSURE > 4,000 psi	VMG- *- FSD- HP		
NOTE: Locking sleeves available in plastic or stainless steel, see Technical Bulletin 25 50. * Please specify number of contacts.			



**THIS PAGE INTENTIONALLY LEFT BLANK**

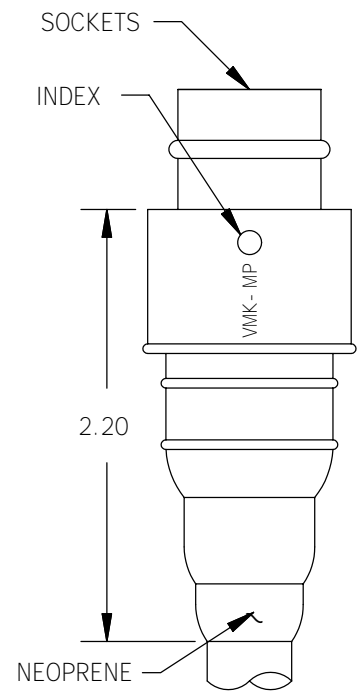
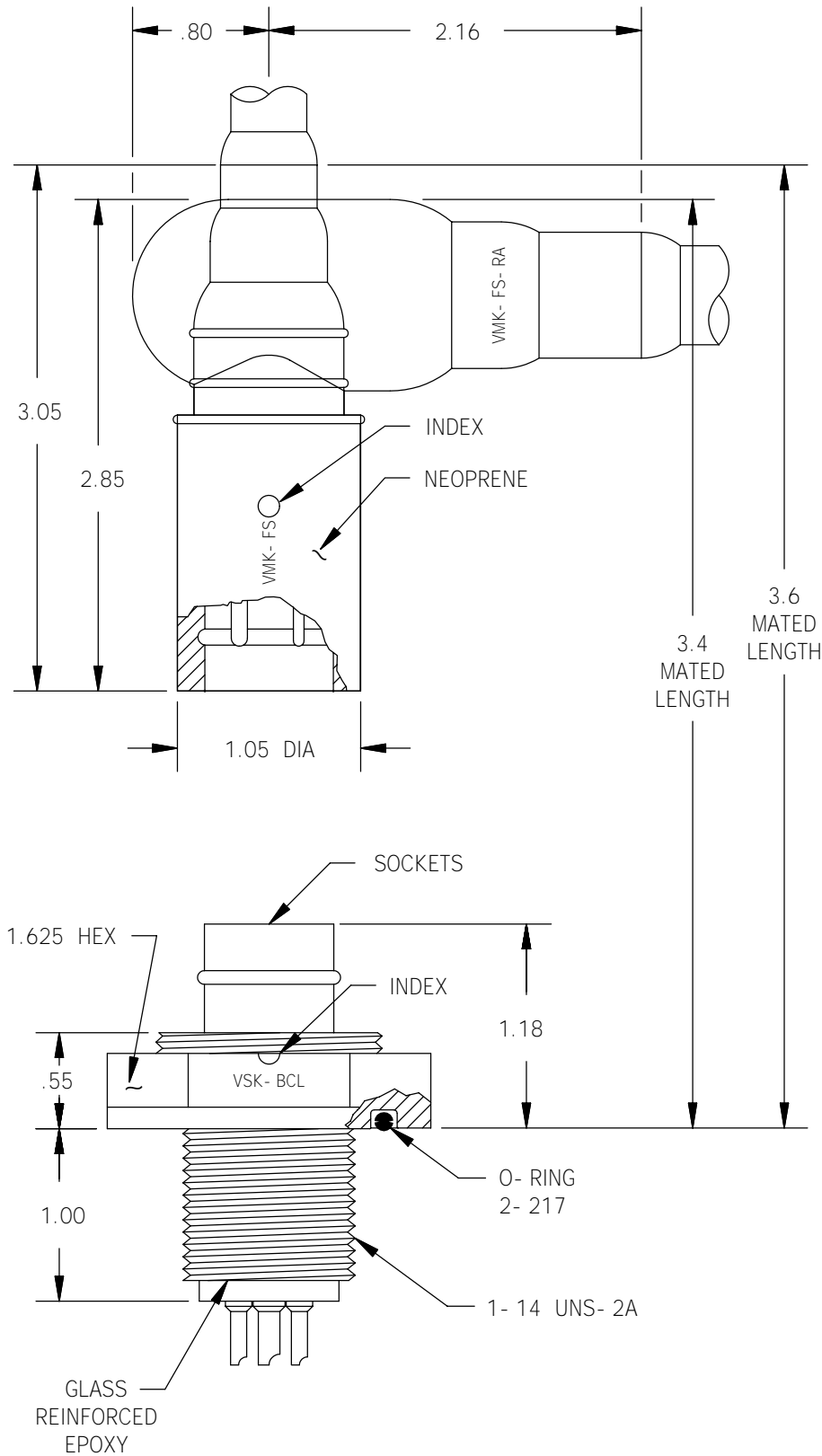

FIELD INSTALLABLE

CONTACT CONFIGURATION  
(FACE VIEW- BCL)

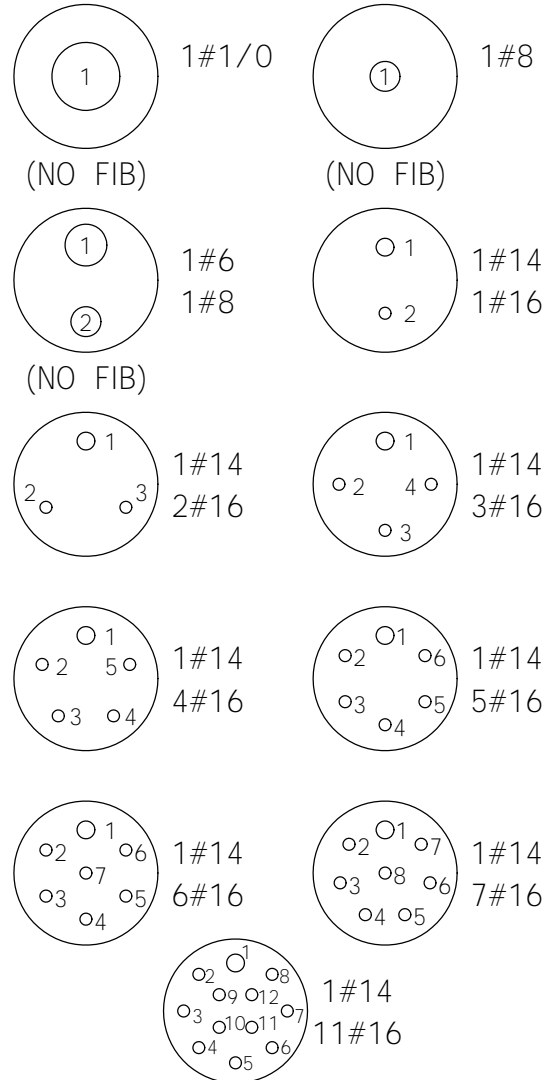
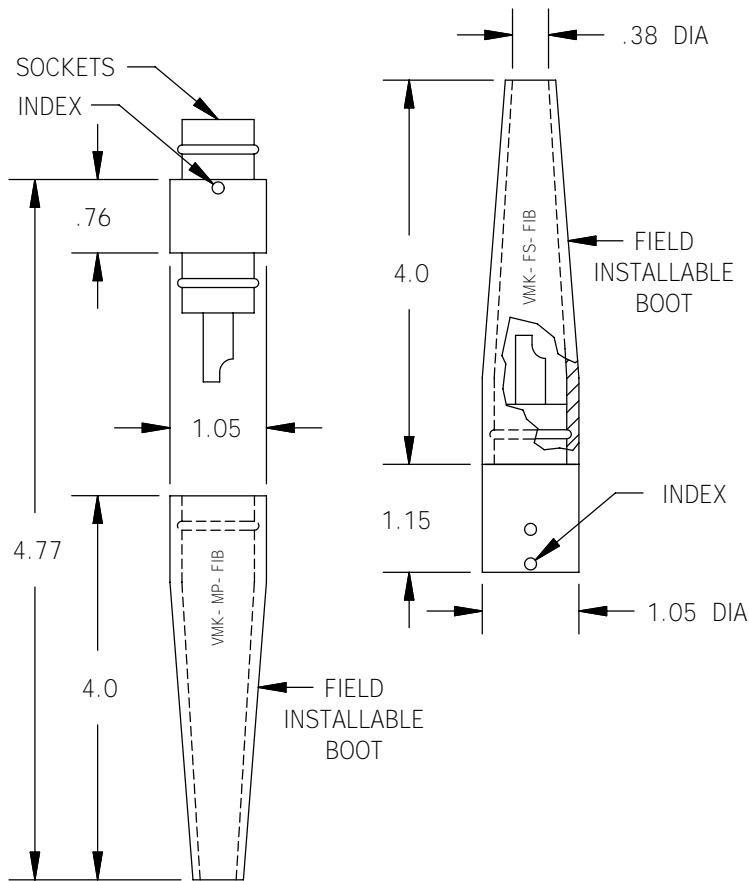

MOUNTING TORQUE FOR VSK- BCL	not to exceed 130 in lbs	MATED PRESSURE RATING (psi) FOR VSK- BCL	10,000
DUMMY PLUG FOR VSK- BCL, VMK- MP		DUMMY PLUG FOR VMK- FS	
LOW PRESSURE < 4,000 psi	VMK- FSD- LP	VMK- *- MPD	
HIGH PRESSURE > 4,000 psi	VMK- *- FSD- HP		
NOTE: Locking sleeves available in plastic or stainless steel, see Technical Bulletin 25 50. * Please specify number of contacts.			

# LOCKING SLEEVES

## PLASTIC LOCKING SLEEVES

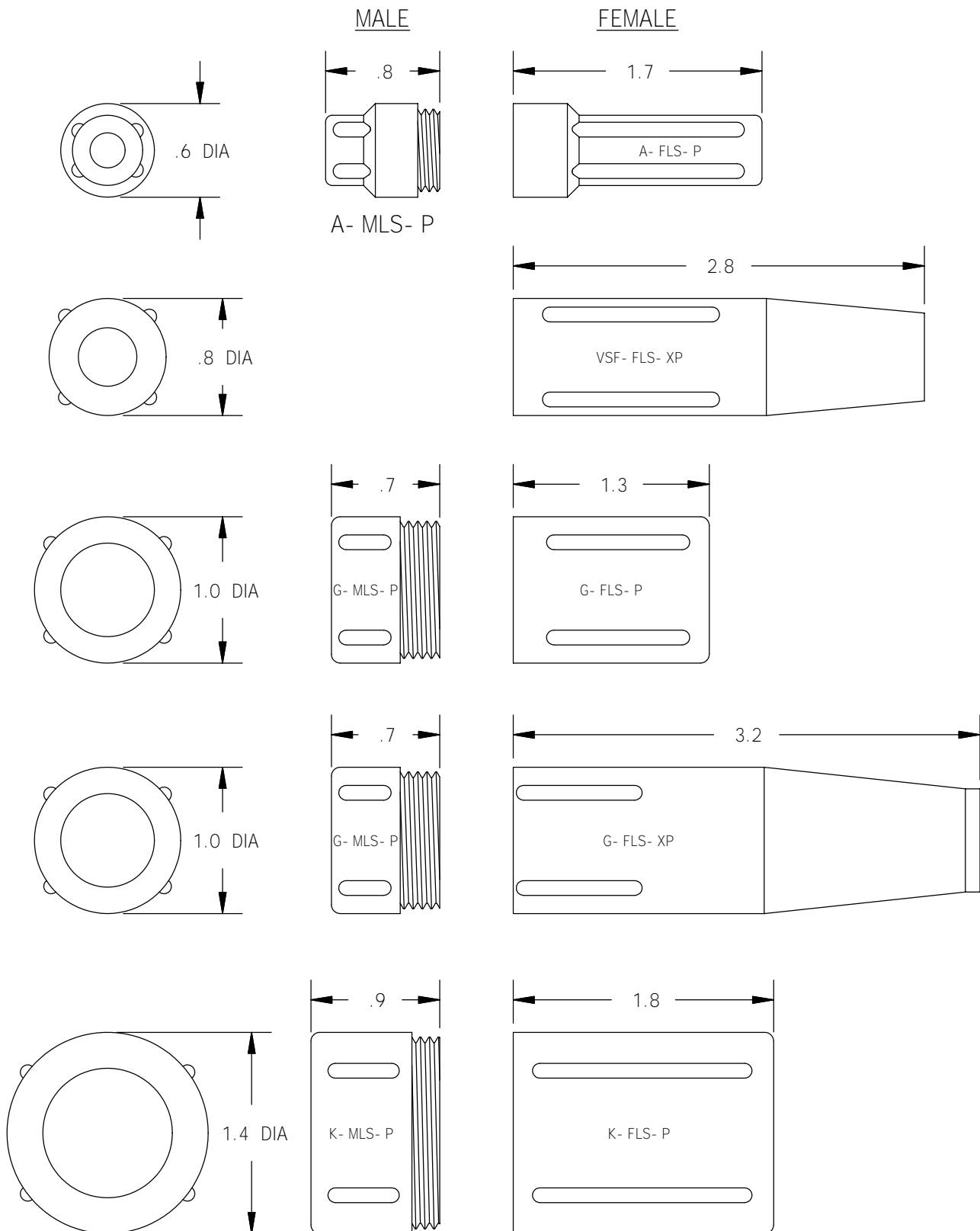

# LOCKING SLEEVES

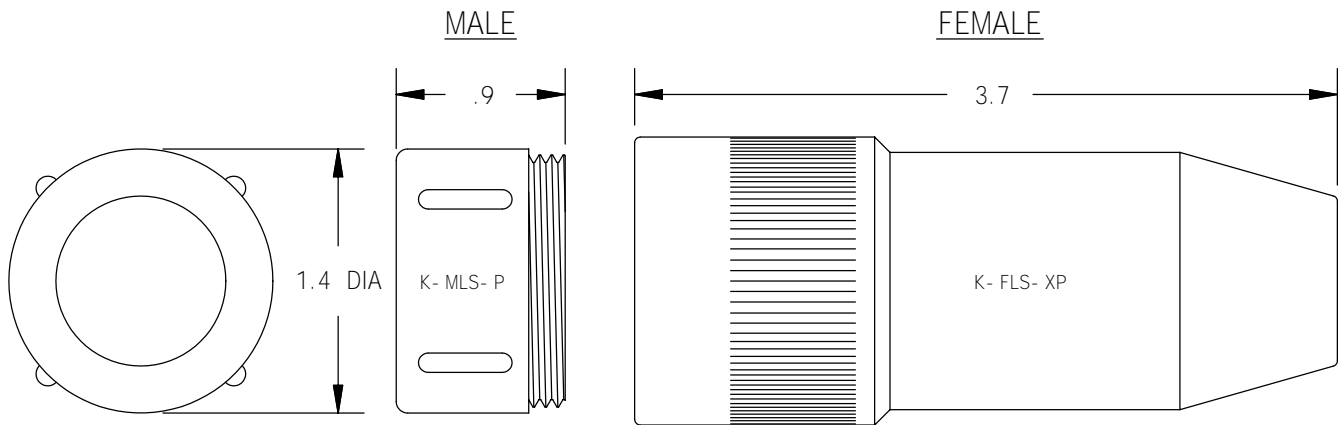

NOTE: XP is recommended to reduce conductor to contact fatigue.

## STAINLESS STEEL LOCKING SLEEVES

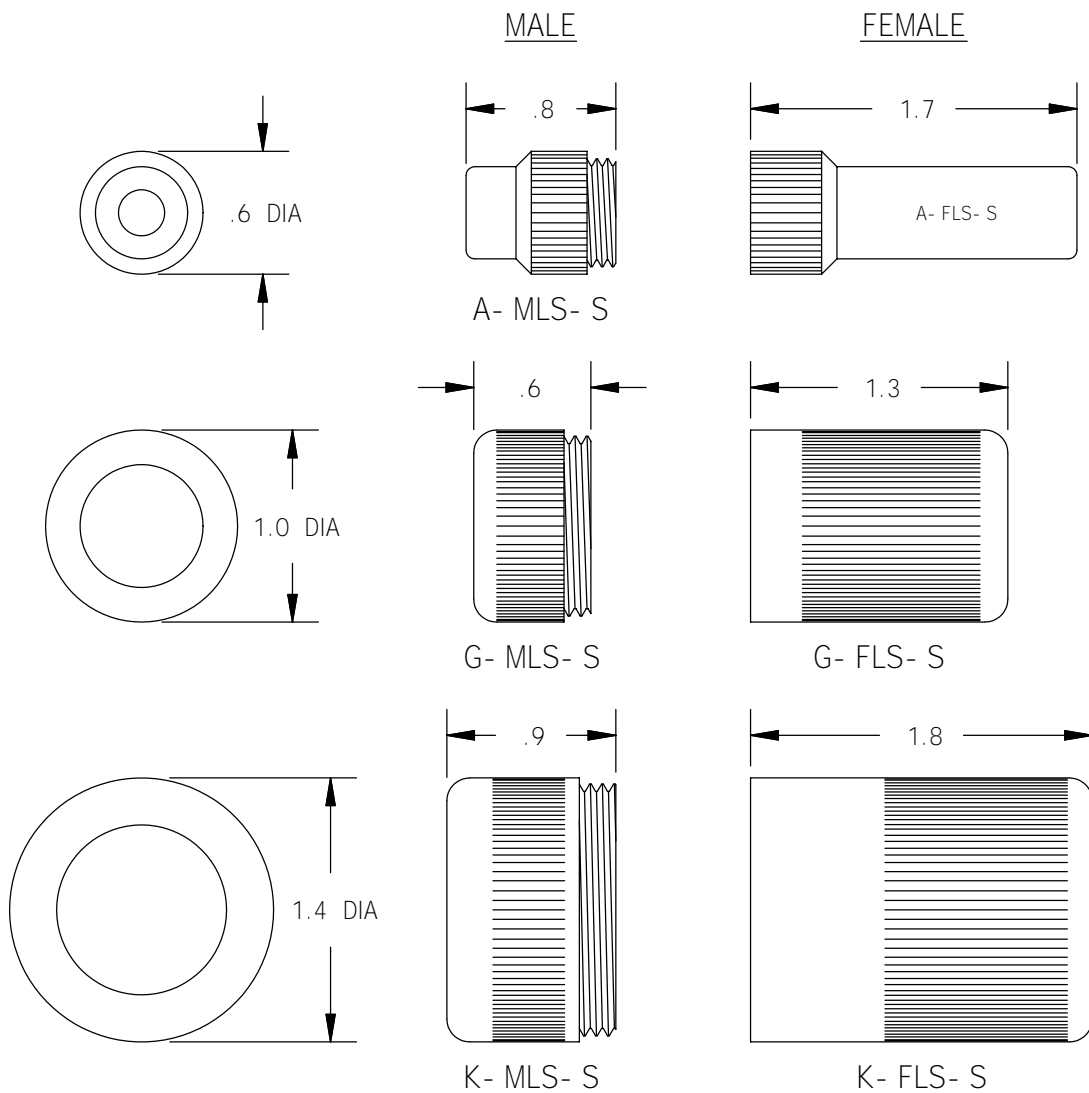

**THIS PAGE INTENTIONALLY LEFT BLANK**