

- DESCRIPTION AND MATERIAL
- Identical to XS-RM connectors except sockets replace pins.
 - Molded neoprene or polyurethane (for G-size) inline connectors and glass reinforced epoxy, stainless steel or aluminum bulkhead connectors.
 - One to twelve contacts.
 - Up to 600 VDC (For higher voltages, contact factory).
 - Up to 10,000 PSI in mated condition.
 - Bulkhead connector design open face pressure rated to 5000 psi.
 - Contacts gold plated per MIL-G-45204.
 - Field installable connectors with locking sleeve available.
 - Field installable connectors have a removable tapered boot for easy access to solder pots during field installation.
- CABLE
- Connector's amperage and voltage may be limited by amperage and voltage rating of cable to which connector is molded.
 - Inline connectors in this series, except field installables, are provided on a standard 24" length of 18 AWG SO cable unless otherwise specified. (Note: VMA provided on 24" length of 20 AWG.)
- USES
- Light to medium duty applications.
 - Hazardous environment.
 - Power transmission.
 - Signal telemetry.
 - FIB – Field installable applications.
- GUIDELINES
- All mounting surfaces require a 32 finish.
 - Accomplish mating with minimum twisting and flexing.
 - Align indexes.
 - Because sockets replace pins in this series, there is less damage potential in unplugged conditions.
 - FS can trap water (suggest flush with alcohol and blow dry).
 - Lubricate MP mating side with 3M Silicone Spray or Dow Corning #111 Valve Lubricant or equivalent.
 - Lubricate o-rings with Dow Corning #111 Valve Lubricant or equivalent.
 - Avoid o-ring cuts and nicks.
 - Replace o-rings when re-using connectors.
 - Avoid contact with noxious solvents.
 - Elastomers can be seriously degraded if exposed to direct sunlight or high ozone levels for extended periods of time.

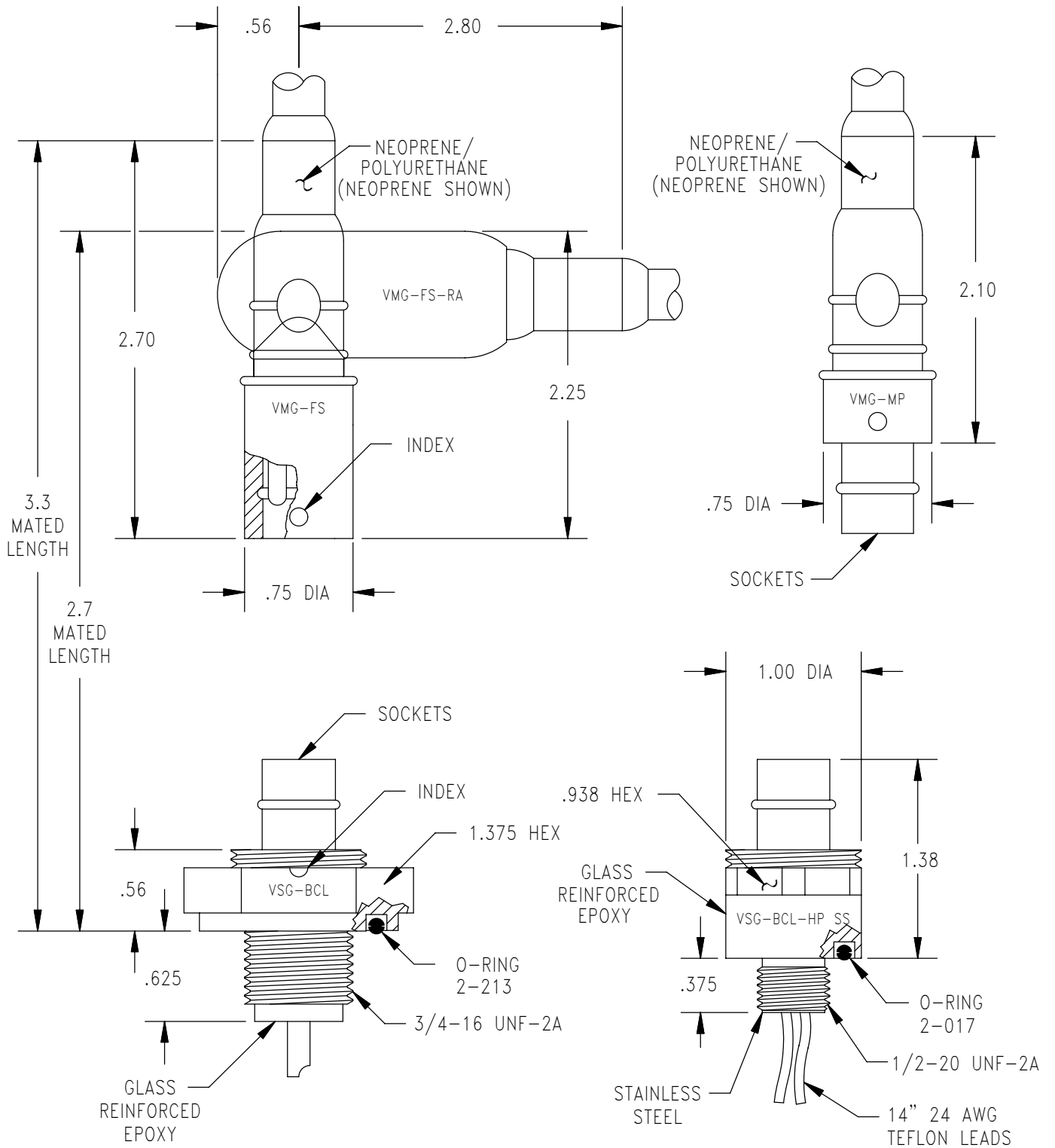

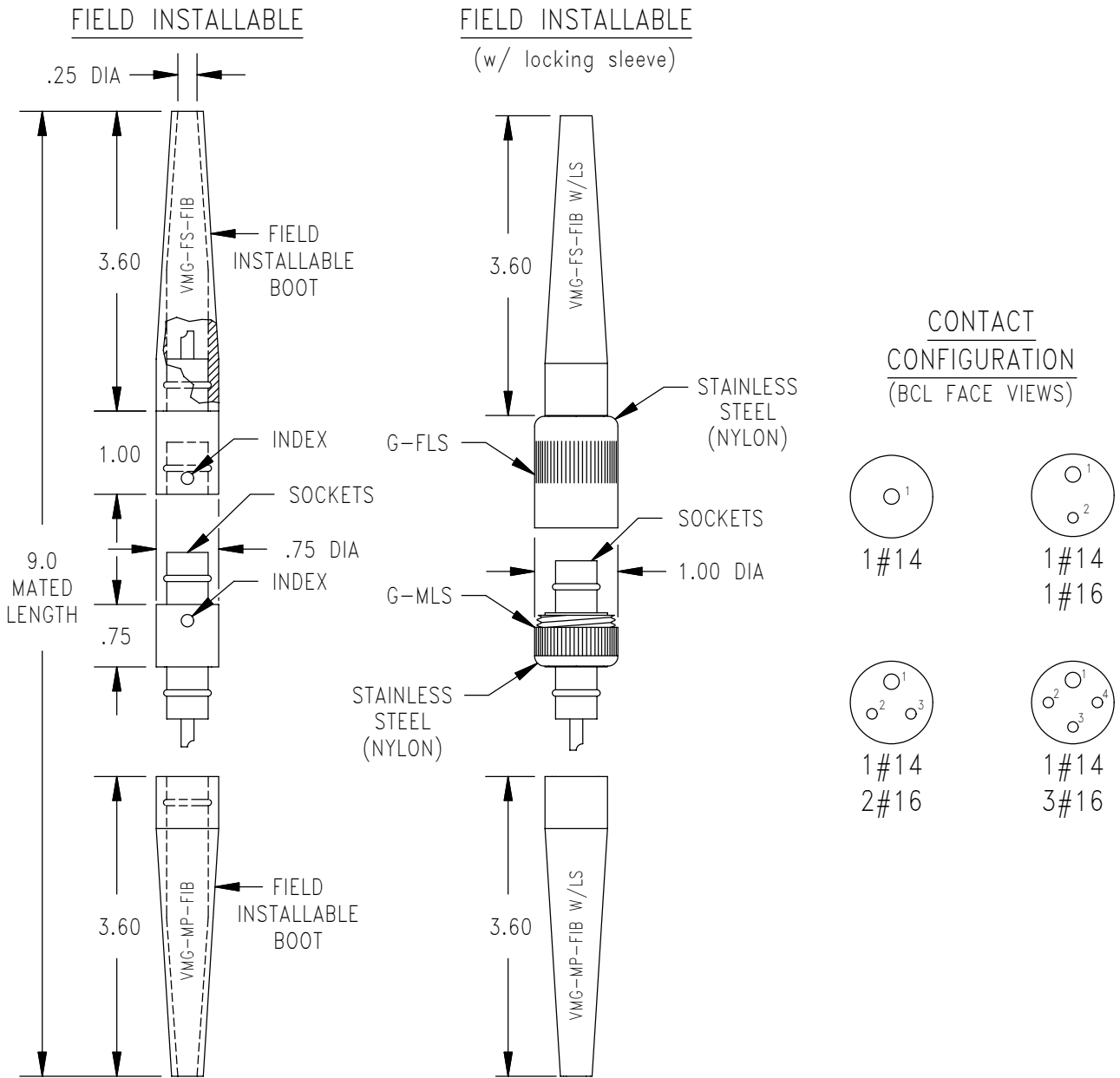

MOUNTING TORQUE FOR VSG-BCL	not to exceed 70 in lbs	MATED PRESSURE RATING (psi) FOR VSG-BCL	10,000
DUMMY PLUG FOR VSG-BCL/BCL HP SS/PBC/PBCL/PBCLM, VMG-MP		DUMMY PLUG FOR VMG-FS	
LOW PRESSURE < 4,000 psi	VMG-FSD-LP	VMG-*-MPD	
HIGH PRESSURE > 4,000 psi	VMG-*-FSD-HP		
NOTE: Locking sleeves available in plastic or stainless steel, see Technical Bulletin 25 50. * Please specify number of contacts.			

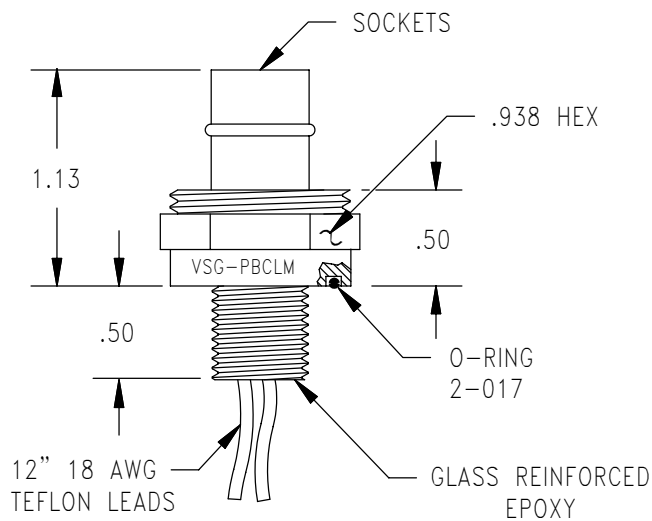
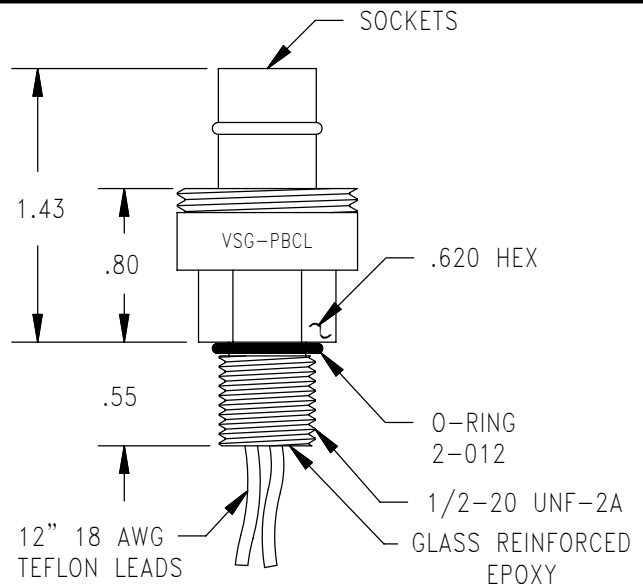
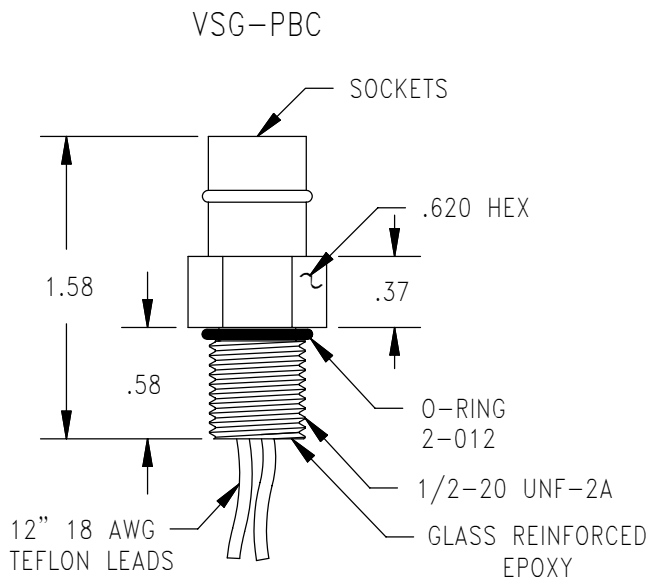

MOUNTING INSTRUCTIONS

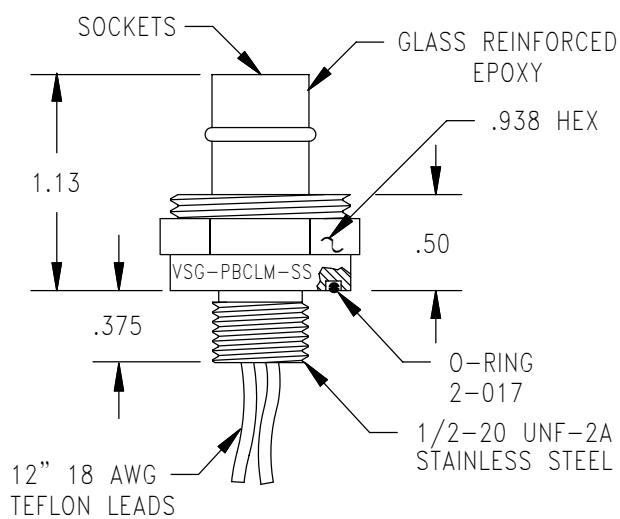
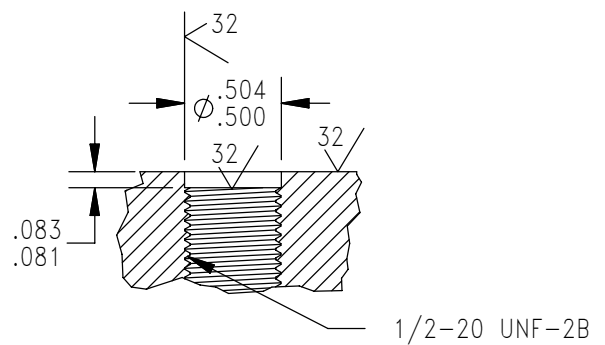

CONTACT CONFIGURATION
(BCL FACE VIEWS)

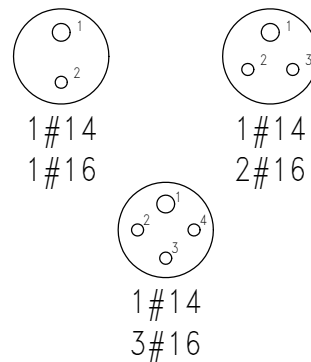

MOUNTING TORQUE FOR VSG-PBC/PBCL/PBCLM	not to exceed 15 in lbs	MATED PRESSURE RATING (psi) FOR VSG-PBC/PBCL/PBCLM	5,000
NOTE: See Technical Bulletin 25 31 for dummy specifications.			