

-
- DESCRIPTION AND MATERIAL
- Molded neoprene or polyurethane (for G-size) inline connectors and glass reinforced epoxy, stainless steel or aluminum bulkhead connectors.
 - One to twelve contacts.
 - Up to 600 VDC (For higher voltages, contact factory).
 - Up to 10,000 PSI in mated condition.
 - Bulkhead connector design open face pressure rated to 5000 psi.
 - Contacts gold plated per MIL-G-45204.
 - Field installable connectors with locking sleeve available.
 - Field installable connectors have a removable tapered boot for easy access to solder pots during field installation.
- CABLE
- Connector's amperage and voltage may be limited by amperage and voltage rating of cable to which connector is molded.
 - Inline connectors in this series, except field installables, are provided on a standard 24" length of 18 AWG SO cable unless otherwise specified. (Note: RMA provided on 24" length of 20 AWG)
- USES
- Light to medium duty applications.
 - Hazardous environment.
 - Power transmission.
 - Signal telemetry.
 - FIB – Field installable applications.
- GUIDELINES
- All mounting surfaces require a 32 finish.
 - Accomplish mating with minimum twisting and flexing.
 - Align indexes.
 - Care must be taken not to damage or bend pins in unplugged conditions.
 - FS can trap water (suggest flush with alcohol and blow dry).
 - Lubricate MP mating side with 3M Silicone Spray or Dow Corning #111 Valve Lubricant or equivalent.
 - Lubricate o-rings with Dow Corning #111 Valve Lubricant or equivalent.
 - Avoid o-ring cuts and nicks.
 - Replace o-rings when re-using connectors.
 - Avoid contact with noxious solvents.
 - Elastomers can be seriously degraded if exposed to direct sunlight or high ozone levels for extended periods of time.

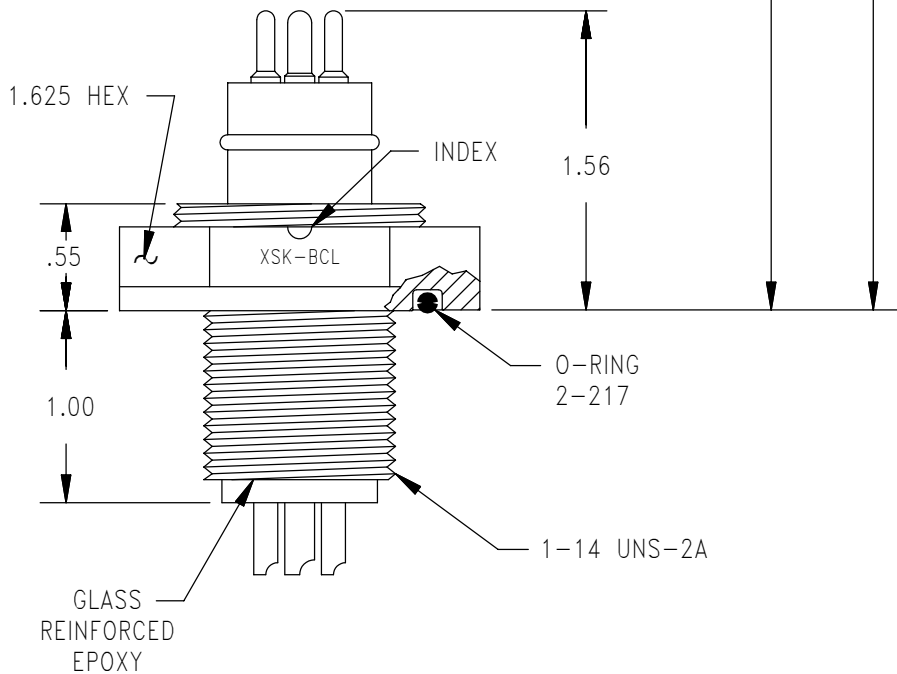

FIELD INSTALLABLE

CONTACT CONFIGURATION
(BCL FACE VIEWS)

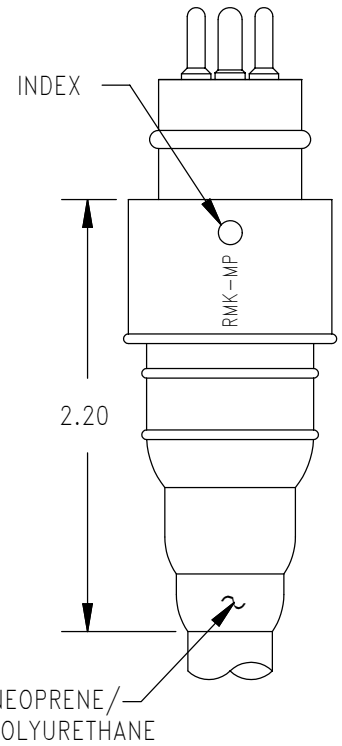
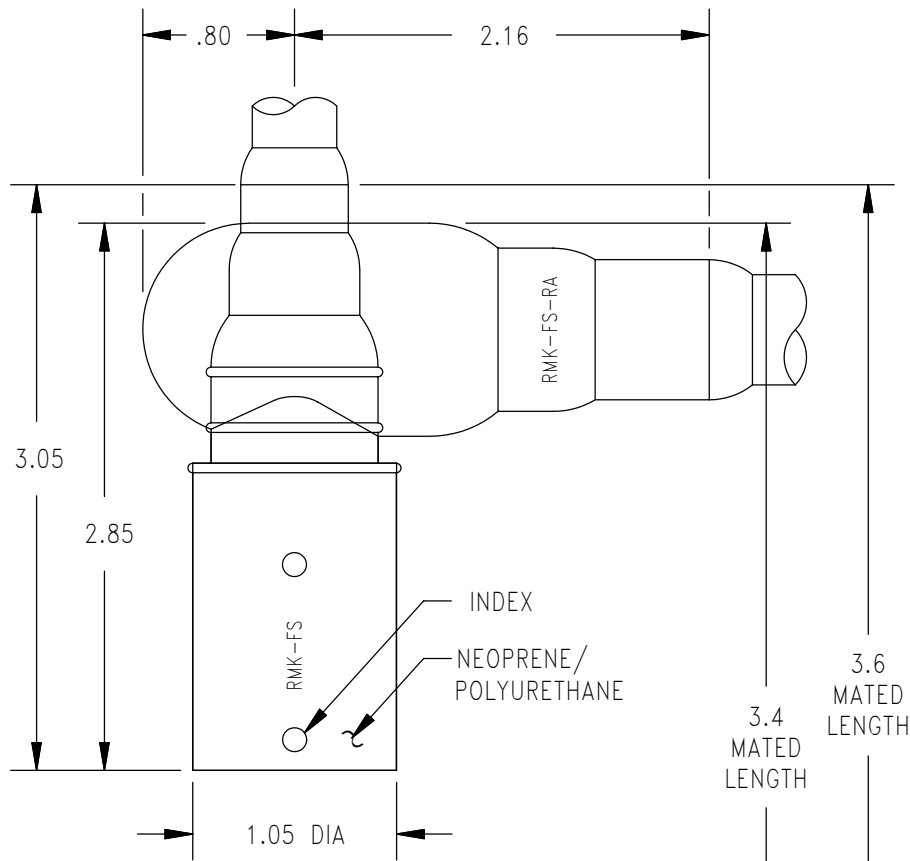
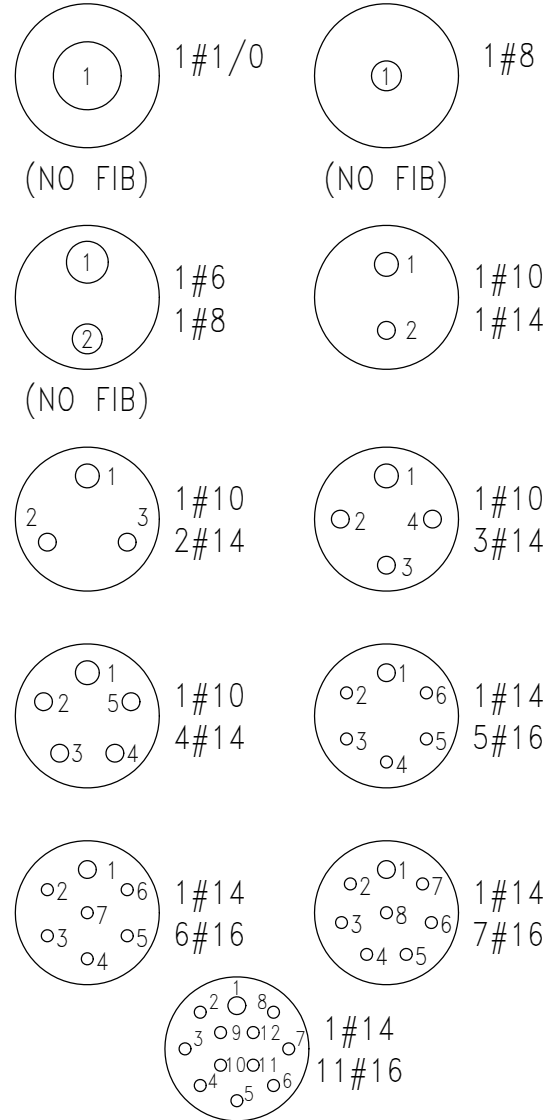
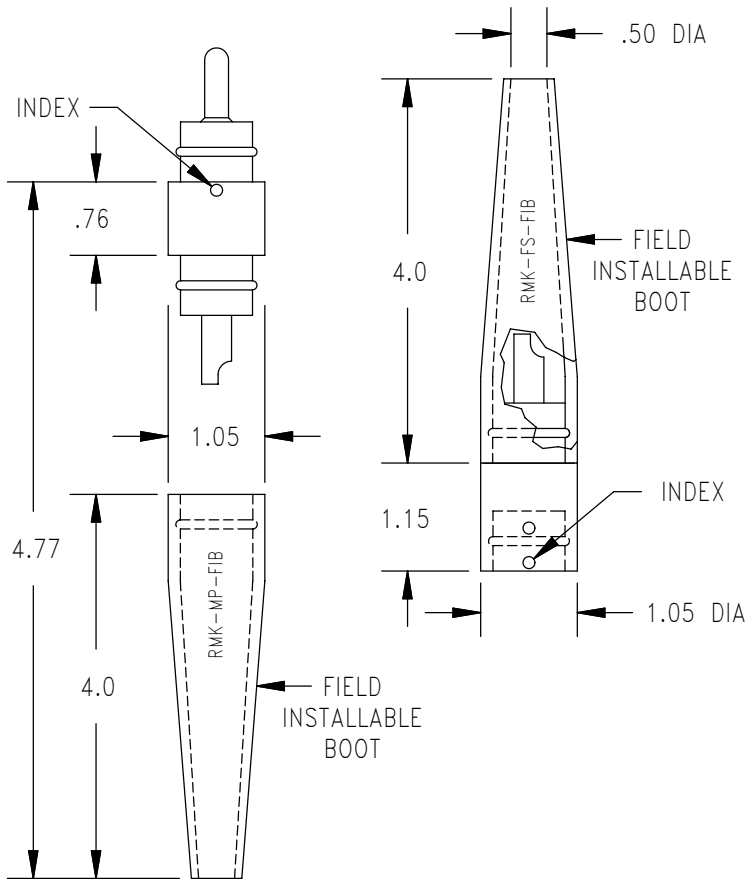

MOUNTING TORQUE FOR XSK-BCL	not to exceed 130 in lbs	MATED PRESSURE RATING (psi) FOR XSK-BCL	10,000
DUMMY PLUG FOR XSK-BCL, RMK-MP		DUMMY PLUG FOR RMK-FS	
RMK-*-FSD		LOW PRESSURE < 4,000 psi	RMK-MPD-LP
		HIGH PRESSURE > 4,000 psi	RMK-*-MPD-HP
NOTE: Locking sleeves available in plastic or stainless steel, see Technical Bulletin 20 40. * Please specify number of contacts.			